



OXYGEN OPTODE 4330, 4835, 4831

1st Edition February 2008 PRELIMINARY
2nd Edition October 2008
3rd Edition February 2009 Including description of Optode 4835
4th Edition August 2012, Including general updates in text, list of scientific publications, description of Optode, Frame Work 3 update, description of Optode 4831, multipoint calibration with improved accuracy and artificial oxygen consumption by sacrificial anode, updated FAQ, Rebranded.

NOTE! The latest version of the FAQ for the Oxygen Optodes is available on our web site.

© Copyright: Aanderaa Data Instruments AS

Contact information:

Aanderaa Data Instruments AS	Visitor address:	TEL: +47 55 604800
PO BOX 34, Slåtthaug	Nesttunbrekken 97	
5851 Bergen, NORWAY	5221 Nesttun, Norway	

E-MAIL: aadi.info@xyleminc.com

WEB: <http://www.aanderaa.com>

Table of Contents

INTRODUCTION	5
Purpose and Scope	5
Document Overview	6
Applicable Documents	7
Abbreviations.....	7
CHAPTER 1 Short Description and Specifications	8
1.1 Pin Configuration	11
1.2 User Accessible Sensor Properties.....	12
1.3 Specifications	15
1.4 Manufacturing and Quality Control.....	15
CHAPTER 2 Measurement Principles and Parameters.....	16
2.1 Sensor Integrated Firmware	17
2.2 Sensor Parameters.....	17
2.3 Salinity Compensation of Data.....	18
2.4 Depth Compensation of Data.....	18
CHAPTER 3 SEAGUARD® Applications.....	20
3.1 Installation on SEAGUARD® Platform.....	20
3.2 RedReference, Calibration Coefficients and Salinity Compensation	22
CHAPTER 4 Sensor configuration using Real-Time Collector.....	25
CHAPTER 5 Connection to PC	27
5.1 RS232 Communication Setup.....	27
5.2 Passkey for Write Protection.....	28
5.3 Save and Reset	29
5.4 Communication Sleep.....	29
5.5 Available Commands for the Oxygen Optodes	30
5.5.1 The Get Command	31
5.5.2 The Set Command.....	31
5.5.3 Formatting the Output String.....	32
5.5.4 XML Commands	32
5.6 Scripting -sending a string of commands	32
5.7 Sensor Configuration	33
CHAPTER 6 Maintenance.....	35
6.1 Changing the Sensor Foil	37
6.1.1 Procedure for Oxygen Optode 4330 and 4831.....	37
6.1.2 Procedure for Oxygen Optode 4835	39
6.2 Function Test.....	40
6.2.1 SEAGUARD® Applications.....	40
6.2.2 Calibration Procedure using a Terminal Program.....	42

Appendix 1 Theory of Operation.....	45
Luminescence Decay Time	46
Appendix 2 The Optical Design	48
Appendix 3 Electronic Design.....	50
Appendix 4 Mechanical Design of Optode 4330 and 4831	51
Appendix 5 Mechanical Design of Optode 4835	52
Appendix 6 Primer –Oxygen Calculations in the Sensor.....	53
Appendix 7 Multipoint Calibration	56
Appendix 8 Illustrations.....	57
Appendix 9 Frequently Asked Questions –FAQ	62
Appendix 10 List of scientific papers	77
Appendix 11 Product Change Notification: Framework 3.....	79
Appendix 12 Oxygen Dynamics in Water	81
Seawater and Gases.....	81
Tables	81

INTRODUCTION

Purpose and Scope

This document is intended to give the reader knowledge of how to operate, calibrate and maintain the Aanderaa Oxygen Optodes 4330, 4835 and 4831. It also aims to give insight on how the Oxygen Optode works.

Individually calibrated commercially available optical dissolved oxygen Optodes for ocean and fresh water applications were introduced by AADI in 2002. The proven long-term stability (years) and reliability of these sensors has revolutionized oxygen measurements and several thousand are now in use in applications ranging from streams to the deepest oceanic trenches on earth, from fish farms to waste water, from polar ice to hydrothermal vents.

In 2002 the first MKI versions of these sensors the models 3830 and 3835 went into service.

This manual deals with the more recent MKII Optode models 4330/4835/4831. Compared to MKI the MKII Optodes' deliver improved electronics, optics, temperature compensation, formulas to calculate absolute oxygen and can be individually multipoint (normally in 40 points at 5 temperatures and 8 oxygen concentrations) calibrated to an enhanced accuracy.

With this revision Aanderaa is releasing a new firmware version to accommodate higher security and future expansion. Both the Smart Sensor Terminal protocol and the AADI Real Time protocol are updated in this version of the Smart Sensor firmware,

AADI Smart Sensors utilize common communication protocols at the RS232 and RS422 interface where the Smart Sensor Terminal protocol is a simple ASCII command string based protocol and the AADI Real Time is an XML based protocol. The common update of these protocols are called framework 3, and is released August 2012 for most of the AADI smart sensors.(see appendix 11)

Oxygen Optode 4330/4330F fits directly on the SeaGuard top-end plate and is interfaced by means of a reliable CANbus interface (AiCaP), using XML for plug and play capabilities. It can also be used as stand-alone sensor using RS-232 output. The sensor is available in three different depth ratings, 300 meter, 2000 meter and 6000 meter. Oxygen Optode 4330 is also available in a fast response version called 4330F.

Oxygen Optode 4835 is the shallow water version of 4330. The sensor housing is made of Hostaform and maximum depth rating is 300 meter. This version fits directly on the SeaGuard SW top-end plate and is interfaced by means of a reliable CANbus interface (AiCaP), using XML for plug and play capabilities. It can also be used as stand-alone sensor using RS-232 output.

Oxygen Optode 4831/4831F is a version build on the same platform as 4330 but with a wet mate connector for easy integration. This sensor has analog and RS-232 output. The sensor is available in three different depth ratings, 300 meter, 2000 meter and 6000 meter. Oxygen Optode 4831 is also available in a fast response version called 4831F.

Document Overview

Chapter 1 is a short description of the sensors covered by this manual.

Chapter 2 is a description of measurement principles and parameters

Chapter 3 is a short description of how to use the sensor with SeaGuard.

Chapter 4 describes how to configure and use the sensor together with AADI Real-Time Collector.

Chapter 5 describes the connection to PC and the RS-232 communication protocol.

Chapter 6 describes maintenance, procedure for changing foil and functional test for the sensors.

The Appendix includes the principle behind the Oxygen Optodes, electronic and mechanical design, calibration procedures including the Stern-Volmer Uchida formula implemented with the new Optode framework 3 introduced in August 2012. The new firmware also allows an optional high accuracy multipoint calibration. The appendix also include illustrations of all available cables, Frequently Asked Questions, a list of scientific publications in which Aanderaa Optodes have played a central role and the PCN covering the updates following introduction of framework 3.

Applicable Documents

V-9867	Assembly Drawing 4330/4330F
V-10362	Assembly Drawing 4835
V-11294	Assembly Drawing 4831
V-8700	Sensor Cable 3855, Sensor to PC, RS-232, for 4330/4835, laboratory use
V-10501	Sensor Cable 4865, Sensor to PC, RS-232, for 4330/4835, field use
V-10331	Sensor Cable 4762, Sensor to free end, for 4330/4835
V-10388	Sensor Cable 4793 for 4330/4835 remote sensor used on SeaGuard
V-11367	Sensor Cable 5280 for 4831, Sensor to IE55
DID-50042	Sensor Cable 5336 for 4831, Sensor to IE55 plus Mecca
DID-50041	Sensor Cable 5335, Sensor to PC, RS-232 for 4831
Form 712	Test & Specification Sheet, Oxygen Optode
Form 770	Calibration Certificate, O2 Sensing foil 3853
Form 710	Calibration Certificate, Oxygen Optode
D 378	Data sheet Oxygen Optode 4330/4330F
D 403	Data sheet Oxygen Optode 4831/4831F
D 385	Data sheet Oxygen Optode 4835

Abbreviations

O₂	Oxygen molecule
LED	Light Emitting Diode
ADC	Analogue to Digital Converter
DSP	Digital Signal Processor
EPROM	Erasable Programmable Read Only Memory
ASCII	American Standard Code for Information Interchange
MSB	Most significant bit
UART	Universal Asynchronous Receiver/Transmitter
RTC	Real Time Clock
FAQ	Frequently Asked Questions; documented in appendix of this OM
AiCaP	Automated idle line CANbus Protocol; A modified communication protocol developed by AADI for a distributed network of smart sensors when connected to SEAGUARD® or SMARTGUARD® loggers.
RDCP	Recording (acoustic) Doppler Current Profiler is a instrument from AADI to measure ocean currents in multiple levels, waves and tides along with other parameters.
RCM	Recording Current Meter is the common terminology for single point current meters from AADI.

CHAPTER 1 Short Description and Specifications

The Oxygen Optode is an optical sensor that does not consume oxygen. The measurement principle is based on fluorescence quenching see appendix 1, while traditional polarographic oxygen sensors, often called Clark sensors, based on electrochemical principles consume oxygen.

The optical oxygen sensors described herein belong to the AADI series of smart multi-parameter sensors.

Apart from a high quality temperature channel which is almost always included for automatic compensation in all of AADI's series of smart sensors; AADI produces other smart sensors to measure water Currents, Conductivity, Wave/Tide and Pressure.

Features common to these sensors include:

- Internal Digital Signal Processor (DSP) to optimise data acquisition and improve accuracy, resolution and stability
- Multi-parameter outputs measured/calculated/presented within the sensor e.g. for oxygen O₂ in µM, O₂ in % saturation, Temperature and Raw data
- Calibration coefficients and unique sensor identification number
- Autonomous sampling, 1 second to 4 hour sampling interval
- AiCaP (CAN bus) communication which means that up to 20-25 sensors can be “plug and play” connected to AADI SEAGUARD® or to a SMARTGUARD® logger that automatically detects and recognizes the sensor.
- RS232 serial communication so that these sensors can be connected directly to computers or third party platforms e.g. data loggers from other manufacturers, gliders, floats, buoys, landers, cable operated and autonomous vehicles,
- Optional Analog 0-5 V, 4-20 mA adaptors available for 4330 and 4835



Figure 1-1 Illustration of the Oxygen Optode 4330.

PIN CONFIGURATION

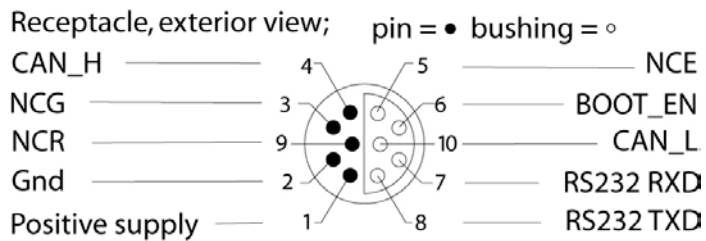

Figure 1-1A Oxygen Optode 4330 Pin Configuration



Figure 1-2 Illustration of the Oxygen Optode 4831

PIN CONFIGURATION SUBCONN MCBH8

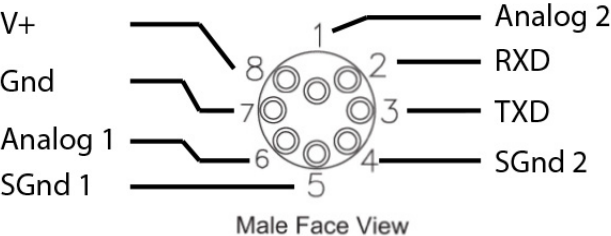

Figure 1-2A Oxygen Optode 4831 Pin Configuration

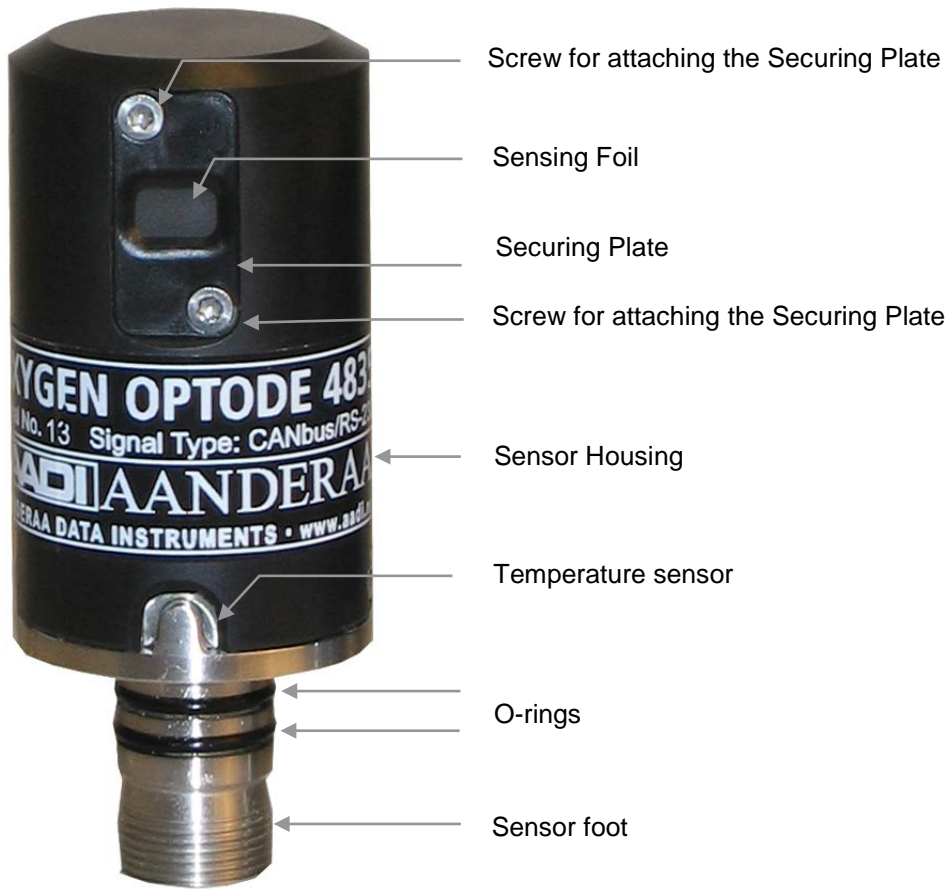

Figure 1-3 Illustration of the Oxygen Optode 4835.

PIN CONFIGURATION

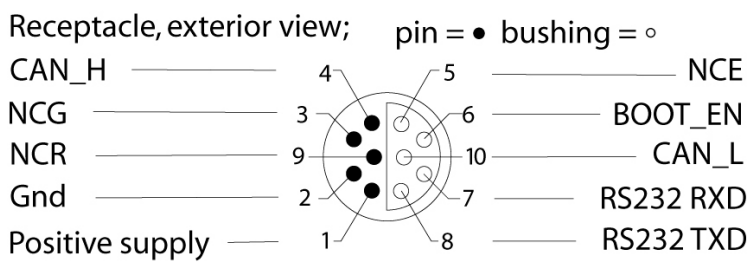

Figure 1-3A Oxygen Optode 4835 Pin Configuration

1.1 Pin Configuration

The Oxygen Optode 4330, 4831 and 4835 pin configuration is given in Figure 1-1A, 1-2A and 1-3A above. A description of the receptacle notation is given in Table 1-1.

Table 1-1 Description of the Pin Configuration

Signal	Description
CAN_H	CANbus line (dominant high)
NCG	Node Communication Ground
NCR	Node Communication Request
Gnd	Ground
Positive supply	5-14V positive supply
NCE	Node Communication Enable
BOOT_EN	Boot Load Enable (do not connect)
CAN_L	CANbus line (dominant low)
RS232 RXD	RS232 Receive line
RS232 TXD	RS232 Transmit line
Analog 1	Analog output no. 1, 0-5V
SGnd 1	Signal ground for Analog output no. 1
Analog 2	Analog output no. 2, 0-5V
SGnd 2	Signal ground for Analog output 2

1.2 User Accessible Sensor Properties

All configuration settings that determines the behavior of the sensor are called properties and are stored in a persistent memory block (flash). One property can contain several data elements of equal type (Boolean, character, integer etc.). The different properties also have different access levels. Table 1-2 lists all user accessible properties for Oxygen Optode 4330, 4831 and 4835.

Table 1-2 FC = Factory Configuration, UM = User Maintenance, SC = System Configuration, DS = Deployment Setting. ENUM=Enumeration, INT =Integer, BOOL=Boolean('yes'/'no')

Property	Type	No of elements	Use	Category	Access Protection RS232 applications
<i>Product name</i>	String	31	AADI Product name	FC	Read Only
<i>Product Number</i>	String	6	AADI Product number		
<i>Serial Number</i>	INT	1	Serial Number		
<i>SW ID</i>	String	11	Software Identifier		
<i>SW Version</i>	INT	3	Software version (Major, Minor, Built)		
<i>HW ID X</i>	String	19	Hardware Identifier, X=1..3		

<i>HW Version X</i>	String	9	Hardware Identifier, X=1..3		
<i>System Control</i>	INT	3	For internal use		
<i>Production Date</i>	String	31	AADI Production Date, format YYYY-MM-DD		
<i>Last Service</i>	String	31	Last service date, format YYYY-MM-DD, empty by default		
<i>Last Calibration</i>	String	31	Last calibration date, format YYYY-MM-DD		
<i>Calibration Interval</i>	INT	1	Recommended Calibration Interval in Days	FC	Read Only
<i>Node Description</i>	String	31	User text for describing node, placement etc.	UM	High
<i>Interface</i>	ENUM	1	Sensor interface. Select either RS232 or RS422 (N/A for Oxygen Optode)	UM	High
<i>Baudrate</i>	ENUM	1	RS232 baudrate: 300,1200,2400,4800,9600,57600,115200 ¹⁾	UM	High
<i>Flow Control</i>	BOOL	1	RS232 flow control: None or Xon/Xoff	UM	High
<i>Enable Comm Indicator</i>	BOOL	1	Enable the Communication Sleep ('%') and Communication Ready ('!') indicators	UM	High
<i>Comm TimeOut</i>	ENUM	1	RS232 communication activation timeout: Always On,10 s,20 s,30 s,1 min,2 min,5 min,10 min	UM	High
<i>Salinity</i>	Float	1	Salinity (PSU) for use in salinity compensation of O ₂ concentration	UM	High
<i>TempCoef</i>	Float	6	Curve fitting coefficients for the temp measurements.	UM	High
<i>PhaseCoef</i>	Float	4	Linearization coefficients for calculating compensated phase	UM	High
<i>PTC0Coef</i>	Float	4	Raw phase temperature compensation coefficients, normally not used (0,0,0,0)	UM	High
<i>PTC1Coef</i>	Float	4	Raw phase temperature compensation coefficients, normally not used (1,0,0,0)	UM	High
<i>PhaseCoef</i>	Float	4	Linearization coefficients for calculating compensated phase	UM	High
<i>FoilID</i>	String	9	Sensing Foil Identifier	UM	High
<i>FoilCoefA</i>	Float	14	Foil coefficients, general curve fit function, set A	UM	High
<i>FoilCoefB</i>	Float	14	Foil coefficients, general curve fit function, set B	UM	High
<i>FoilPolyDegT</i>	INT	28	Exponents for temperature, general curve fit function	UM	High
<i>FoilPolyDegO</i>	INT	28	Exponents for oxygen, general curve fit function	UM	High
<i>SVUFoilCoef</i>	Float	7	Foil coefficients for the 'Stern Volmer Uchida' formula	UM	High

<i>ConcCoef</i>	Float	2	Linear adjustments coefficients for final O ₂ concentration calculation, nominal values 0 (offset) and 1 (slope).	UM	High
<i>NomAirPress</i>	Float	1	Nominal air pressure for use in O ₂ concentration calculations	UM	High
<i>NomAirMix</i>	Float	1	Nominal O ₂ percentage in air for use in O ₂ concentration calculations	UM	High
<i>CalDataSat</i>	Float	2	Two point calibration data, raw phase and temperature @ 100% air saturation	UM	High
<i>CalDataAPress</i>	Float	1	Two point calibration data, air pressure (hPa)	UM	High
<i>CalDataZero</i>	Float	2	Two point calibration data, raw phase and temperature @ 0% air saturation	UM	High
<i>Enable RedReference</i>	BOOL	1	Controls the use of the red reference LED	UM	High
<i>RedReference Interval</i>	INT	1	Sample interval divisor for use of red reference. Examples: Value 1 for using red reference for each sample. Value 10 for using red reference for each 10 th sample.	UM	High
<i>Mode</i>	ENUM	1	Operation Mode: 'AiCaP', 'Smart Sensor Terminal', 'AADI Real-Time', 'Analog Output' see chapter 5.7	SC	Low
<i>Enable Sleep</i>	BOOL	1	Enable sleep mode	SC	Low
<i>Enable Polled Mode</i>	BOOL	1	Enable Polled Mode (for RS232), when set to 'no' the sensor will sample at the interval given by the <i>Interval</i> property, when set to 'yes' the sensor will wait for the 'Do Sample' command.	SC	Low
<i>Enable Text</i>	BOOL	1	Enable text, when set to 'no' the start up info and the parameter text is removed	SC	Low
<i>Enable Decimalformat</i>	BOOL	1	Controls the use of decimal format in the output string	SC	Low
<i>Analog TempLimit</i>	Float	2	Lower and upper ranger limits for analog temperature output (Output 2), default -5 to 35°C *2)	SC	Low
<i>Analog Output1</i>	ENUM		Controls which parameter is presented at analog Output 1; O ₂ Concentration, AirSaturation, CalPhase, Fixed1, Fixed2 ²⁾	SC	Low
<i>Analog Coef</i>	Float		Coefficients (offset,slope) used for trimming the analog outputs, default set to 0,1 ²⁾	SC	Low
<i>Enable AirSaturation</i>	BOOL	1	Controls inclusion of air saturation(%) in the output	SC	Low
<i>Enable Rawdata</i>	BOOL	1	Controls inclusion of raw data in the output string	SC	Low
<i>Enable Temperature</i>	BOOL	1	Controls inclusion of Temperature in the output	SC	Low

<i>Enable HumidityComp</i>	BOOL	1	Enable compensation for vapour pressure,-disable only for use in dry air or external humidity compensation	SC	Low
<i>Enable SVUformula</i>	BOOL	1	Refer Appendix 7	SC	Low
<i>Interval</i>	Float	1	Sampling Interval in seconds	DS	No
<i>Owner</i>	String	31	Set the device owner	DS	No
<i>Location</i>	String	31	Set the location	DS	No
<i>Geographic Position</i>	String	31	Set the geographic position	DS	No
<i>Vertical Position</i>	Float	1	User value for describing sensor position	DS	No

¹⁾ Note! Baud rates lower than 9600 may limit the sampling frequency.

²⁾ Applicable to 4831 only

1.3 Specifications

For product specifications refer Datasheet D378 4330/4330F, D385 4835 and D403 4831/4831F on our web site <http://www.aaderaa.com> or contact aadi.info@xyleminc.com

You will always find the latest versions of our documentation on the web.

Customers can register to obtain a username and password necessary to gain access to product manuals, technical notes and software. Please contact aadi.info@xyleminc.com for guidance.

1.4 Manufacturing and Quality Control

Aanderaa Data Instruments products have a record for proven reliability. With over 40 years experience producing instruments for user in demanding environments around the globe, you can count on our reputation of delivering the most reliable products available.

We are an ISO 9001 Certified Manufacturer. As a company we are guided by three underlying principles: quality, service, and commitment. We take these principles seriously, as they form the foundation upon which we provide lasting value to our customers.

CHAPTER 2 Measurement Principles and Parameters

The AADI Oxygen Optode 4330, 4831 and 4835 are based on the ability of selected substances to act as dynamic fluorescence quenchers.

The fluorescent indicator is a special platinum porphyrin complex embedded in a gas permeable foil that is exposed to the surrounding water. Characteristic features of these foils and sensors are exceptional sensitivity, stability and robustness. Hundreds of examples exist of field stability for periods of 1-6 years (see summary of scientific publications appendix 11). In addition the ability to withstand high temperatures, to have low and fully reversible pressure effects and minimal wet-dry cycling effects are benefits of the AADI Optodes.

The 4330 and 4831 Optodes can be fitted with the standard or faster response foils. The “standard foil” is more robust and recommended in most applications. A black optical isolation coating protects the sensing complex from influences caused by direct incoming sunlight, exciting fluorescent particles in the water, and biofouling. The “faster response” foils are suitable if shorter response times are required however these foils do not have any protective optical isolation layer. Normally the foils have the same long-term stability but the fast foils are slightly noisier. If exposed to direct sunlight they will bleach and drift towards lower responses. It is always recommended to store sensors and spare foils in the dark and to soak sensors in water at least 24 hours prior to calibration or deployment. Sensors are delivered with a reusable black rubber protection cap and it is recommended to add a wet piece of natural sponge to keep the sensor foil wet at all times during storage. For more details on these and other issues please see pages 46 & 47 along with FAQ's in appendix.

The sensing foil is fixed against a sapphire window by four screws and a plastic securing plate, providing optical access to the foil by the measuring system from inside a watertight housing.

The foil is excited by modulated blue light, and the Optode measures the phase shift of a returned red light, ref Appendix 2. By linearizing and temperature compensating, with an incorporated temperature sensor located next to the sensing foil, the absolute O₂ concentration is determined.

The lifetime-based luminescence quenching principle, as used in AADI Oxygen Optodes, offers the following advantages over electrochemical sensors:

- Not stirring sensitive (does not consume oxygen; does not require pumps)
- Direct Measurement of absolute oxygen concentrations without repeated calibrations
- Better long-term stability (stable for years)
- Less affected by pressure; Pressure behavior is predictable and fully reversible
 - Repeatable
 - Low Noise
 - Exceptionally Low Drift

The Optode can be logged directly by a PC (via the RS232 protocol) and by most PLC's, DCP's, I/O devices, data loggers and systems.

2.1 Sensor Integrated Firmware

The main tasks of the sensor's integrated firmware are to control the transmitter, sample the returned fluorescent signal, extract the phase shift of this signal, and convert it into oxygen concentration and/or Air Saturation value.

All the user configurable properties that can be changed for each individual sensor, i.e. calibration coefficients, are called sensor properties. The properties can be displayed and changed using the Smart Sensor Terminal protocol via an RS232 port, refer CHAPTER 5 for communication with the sensor using a terminal communication program. Examples of typical terminal emulation programs are Hyper Terminal and Tera Term

The Oxygen Optode will perform a measurement sample and present the result within the first 1.5 seconds after the Optode has been powered up.

2.2 Sensor Parameters

Engineering data are calculated by firmware in the sensor based on measured raw data and sets of calibration coefficients stored in the sensor:

- The Oxygen content is presented in μM (1 Molar = 1 mole/litre). Conversions to other commonly used engineering unit values are:
 - 1 ml/l = 44.66 μM ,
 - 1 mg/l = 31.25 μM .Please observe that to obtain absolute concentrations of oxygen these values needs to be salinity and pressure compensated (see below).
- The relative Air Saturation is presented in % relative to the nominal air pressure (1013.25 hPa). These values do not need to be salinity compensated.
- The ambient Temperature is presented in $^{\circ}\text{C}$.

The optode raw data are the phase and amplitude of the returned signal after the luminophore quenching:

CalPhase(deg):	Calibrated phase
TCPhase(deg):	Temperature compensated phase
C1RPh(deg):	Phase measurement with blue excitation light
C2RPh(deg):	Phase measurement with red excitation light
C1Amp(mV):	Amplitude measurement with blue excitation light
C2Amp(mV):	Amplitude measurement with red excitation light
RawTemp(mV):	Voltage from thermistor bridge.

The 4831 analog channel 1 may be set to output either; μM or %Saturation or CalPhase.

Calibration coefficients are stored in the sensors flash and are updated when recalibrated. If raw data are not needed the user can select to turn off the delivery and logging of these.

2.3 Salinity Compensation of Data

The O₂ concentration sensed by the Optode is the partial pressure of dissolved oxygen in water.

Since the foil is only permeable to gas and not water, the optode cannot sense the effect of salt dissolved in the water, hence the optode always measures as if immersed in fresh water.

If the salinity variation on site is minor (less than ±1ppt), the O₂ concentration can be compensated in real-time inside the sensor by setting the internal property 'Salinity' to the average salinity at the measuring site.

If the salinity varies significantly, you should simultaneously measure the salinity externally and perform a more accurate correction by a post compensation of the data. An Excel spreadsheet containing the equations for post compensation of the measurements is available for download at the document download site at the Aanderaa Global Library, refer www.aanderaa.com.

If the *Salinity* property in the sensor is set to zero, the compensated O₂ concentration, O_{2c} in μM, is calculated from the following equation:

$$O_{2c} = [O_2] \cdot e^{S(B_0 + B_1 T_s + B_2 T_s^2 + B_3 T_s^3) + C_0 S^2}$$

where:

O₂ is the measured O₂ concentration

S = measured salinity in ppt or PSU

$$T_s = \text{scaled temperature} = \ln \left[\frac{298.15 - t}{273.15 + t} \right]$$

t = temperature, °C

$$B_0 = -6.24097e-3 \quad C_0 = -3.11680e-7$$

$$B_1 = -6.93498e-3$$

$$B_2 = -6.90358e-3$$

$$B_3 = -4.29155e-3$$

If the *Salinity* property in the optode is set to other than zero (zero is the default value), the equation becomes:

$$O_{2c} = [O_2] \cdot e^{(S-S_0)(B_0 + B_1 T_s + B_2 T_s^2 + B_3 T_s^3) + C_0 (S^2 - S_0^2)}$$

Where S₀ is the internal salinity setting.

2.4 Depth Compensation of Data

The response of the sensing foil decreases to some extent with the ambient water pressure (3.2% lower response per 1000 m of water depth or dbar –investigated in detail by Uchida et al., 2008, for full reference see publication list in appendix 11). This effect is the same for all AADI oxygen Optodes and is totally and instantly reversible and easy to compensate for.

The depth compensated O₂ concentration, O_{2c}, is calculated from the following equation:

$$O_{2c} = O_2 \cdot \left(1 + \frac{0.032 \cdot d}{1000} \right)$$

where:

d is depth in meters or pressure in dbar.

O_2 is the measured O_2 concentration in either μM or %.

The unit of the compensated O_2 concentration, O_{2c} , depends on the unit of the O_2 input

NOTE! Depth compensation is not performed within the Optode.

Examples of depth compensation:

At normal atmospheric pressure (1013 mbar) the measured O_2 concentration should not be pressure compensated. As the sensor is submerged you must perform pressure compensation of 0.0032% per dbar or for every meter increase of the relative pressure.

The relative pressure = absolute pressure (measured with the optode) – atmospheric pressure (normally set to 1013 mbar).

Example 1: The measured O_2 concentration with an Optode is 400 μM . The measurement was performed at 1m depth, which is 1dbar relative pressure.

$$O_{2c} = 400 \times 1.000032 = 400.012 \mu\text{M}$$

Example 2: The measured O_2 concentration with the Optode is 400 μM . The measurement was performed at 1000m depth, which is 1000dbar relative pressure.

$$O_{2c} = 400 \times 1.032 = 412.8 \mu\text{M}$$

CHAPTER 3 SEAGUARD® Applications

The optode is equipped with a CANbus interface supporting AADI AiCaP (Automated idle line CANbus Protocol). This standard ensures easy plug and play connection to all AADI SEAGUARD® and SMARTGUARD® data loggers. Refer chapter 3.1 for installation of the Optode on your SEAGUARD® Instrument.

When connected to an AiCaP bus network the Optode will report its capabilities and specifications to the data logger at power up. The data logger assembles the information and provides the user with the possibility to configure the instrument based on the presented nodes. This solution provides for greater flexibility on both use and design of the different elements within the system.

Note! This chapter describes the System Configuration of the Oxygen Optode 4330 and 4835. Refer TD262a for a thorough description of configuring the SEAGUARD® Instrument, and to perform Node Identification, Deployment settings, and Recorder settings.

Note! Metal structures submerged in water (of e.g. Stainless Steel, Aluminium, Bronze) are often corrosion protected by sacrificial anodes. As the anode disintegrates oxygen is consumed at all "naked" exposed metal parts with which the anode is in electrical contact. The oxygen consumption can be significant e.g. during its lifetime, normally 1-2 years, a 130 g Zn anode mounted on a SEAGUARD®/RDCP/RCM pressure case can consume all oxygen in about 700 l of water. In areas where very low circulation conditions exist water parcels with lower oxygen concentrations will form and can surround the oxygen sensors and lead to artificial dips in the oxygen readings. These effects are detectable in environments in which oxygen is stable (e.g. less than 2 % variations over time periods of days-weeks) and when currents are low (e.g. below 10 cm/s). In a vast majority of applications these effects are of low/no significance. Detailed information about this can be found in the appendices.

3.1 Installation on SEAGUARD® Platform

The Oxygen Optode 4330 and 4835 can easily be installed on AADI SEAGUARD® data loggers. Power should be turned off before connecting the sensor. We recommend that you install the Oxygen Optode in sensor position 3, 4 or 6, refer Figure 3-1. If mounted in position 6 use patch cable to connect the optode to the HUB card, for further installation instructions refer TD262a SEAGUARD® Platform Operating Manual.

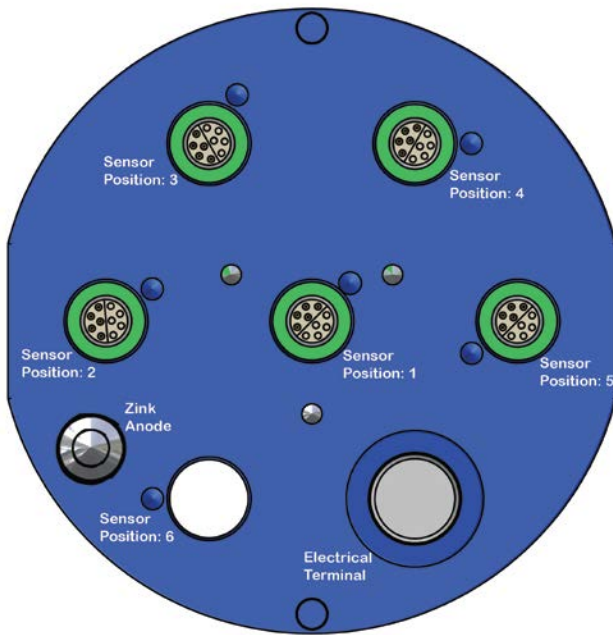

Figure 3-1 Illustration of the SEAGUARD® Top-end plate.

Important!

Refer SEAGUARD® Quick Start, TN301 or the SEAGUARD® Platform Operating Manual, TD262a, for an illustrated sensor installation guide.

TN309 holds an extract of sensor connection / disconnection given in the SEAGUARD® Operating Manual.

Note!

Always replace O-rings when removing, exchanging, or installing a new sensor or a sealing plug.

Apply Tectyl 506 (included in Maintenance Kit) in the slit between the Sensor and the Top-end plate to prevent crevice corrosion of the Top-end plate.

Sensor Configuration

After installing the sensor turn power on and open the **System Configuration** from the **Menu** button. Select the newly installed **Oxygen Optode** which should appear in the list of sensors, and tap **Configure** in the lower part of the window.

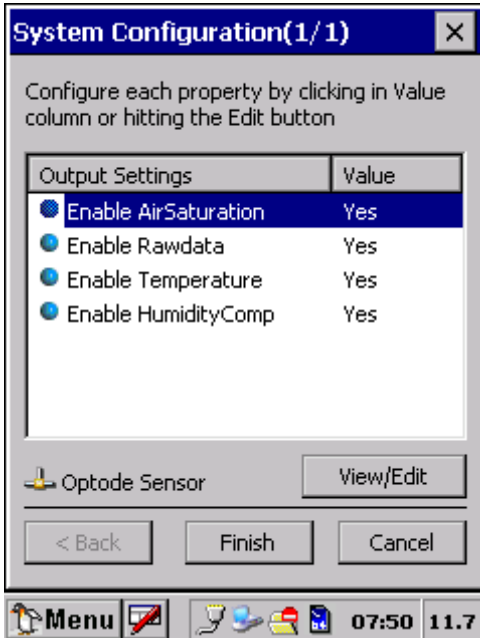

The **System Configuration** holds a list of output parameters that can be enabled/disabled by the user, refer Figure 3-2. Enabled properties (**Yes**) are stored in the data logger:

- **Enable** Air Saturation in engineering units.
- **Enable** Raw data, refer chapter 2.2 .
- **Enable** Temperature in engineering units.
- **Enable HumidityComp** property activates compensation of vapour pressure in the calculations of the output parameters. Enable HumidityComp can be set to **No** if measurements are performed in dry air conditions or if you like to perform the humidity compensation as a post-processing operation. Disabling this will typically lead to 1-3 % lower readings depending on the relative humidity of the air.

Figure 3-2 System Configuration; Output settings.

The absolute oxygen level, μM , is a default parameter and cannot be disabled, refer TD262a.

To enable/disable a parameter:

Select the output parameter from the list, press **View/Edit** in the lower part of the window, and change the setting by clicking the box (box is now checked), press **Save** to save and close the window.

We recommend that you enable all parameters in case of later use. The memory card storage capacity is normally not a limitation for the SEAGUARD[®]. Raw data can be used e.g. to control calibration coefficients and perform quality control on the data.

3.2 RedReference, Calibration Coefficients and Salinity Compensation

Special property settings and calibration coefficients are found in **User Maintenance**.

Open the **User Maintenance** from the **Menu** button. Select the **Oxygen Optode** from the list of sensors, and tap **Configure** in the lower part of the window. The user maintenance holds four submenus:

- **Node Description**
- **Salinity setting**
- **Calibration Coefficients**
- **Enable RedReference**

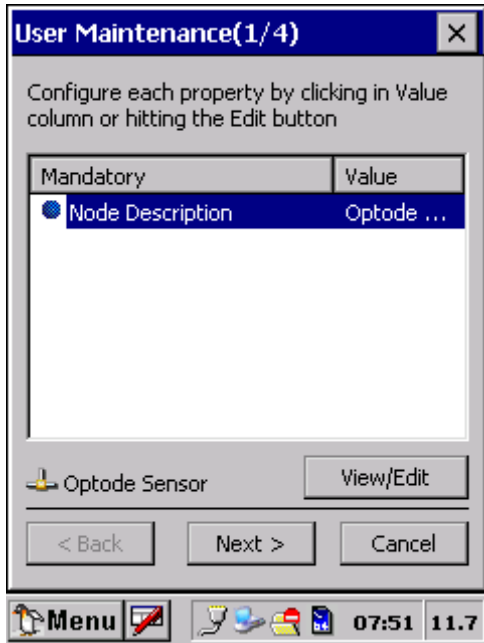

Figure 3-3 Set the Salinity

Select the **Node Description** property, press **View/Edit** in the lower part of the window, and change the setting. Press **Save** to store the setting when completed.

Node Description is a user entered text describing the sensor, placement etc. If using for example a SEAGUARD[®] sensor string with multiple sensors connected; renaming the sensor can facilitate analyzing data. The text is by default set to the product name followed by product- and serial number, e.g. *Optode Sensor 4330#52*.

Press **Next>** to continue with the next submenu.

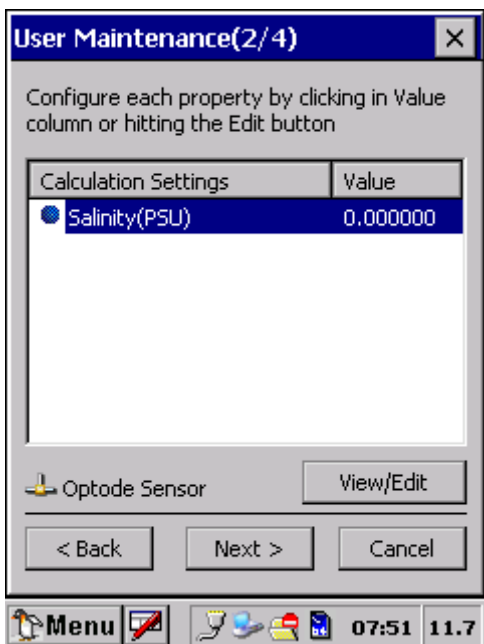

Figure 3-4 Set the Salinity

The second submenu in the Oxygen Optode user maintenance holds a setting for the Salinity:

Select the **Salinity** property, tap **View/Edit** and type the salinity value. Press **Save** to store the setting.

Note! If you are post compensating for the salinity, you should set the property value to 0. When sensors are delivered from the factory they are set to 0 salinity as factory default.

Press **Next>** to continue with the next submenu.

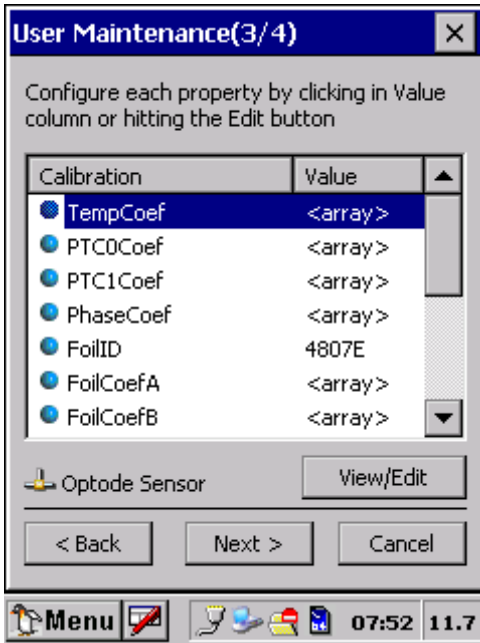

Figure 3-5 Calibration Coefficients

For each calibration property to be set, you must first select the property then press **View/Edit** and type the correct value. Press **Save** to store the settings.

The foil coefficients must be updated when changing the sensing foil.

Press **Next >** to continue with the next submenu.

Note! Foil coefficients can be entered and new calibrations can also be performed if connecting the sensor directly to a computer using a Terminal program, see below for detailed instructions.

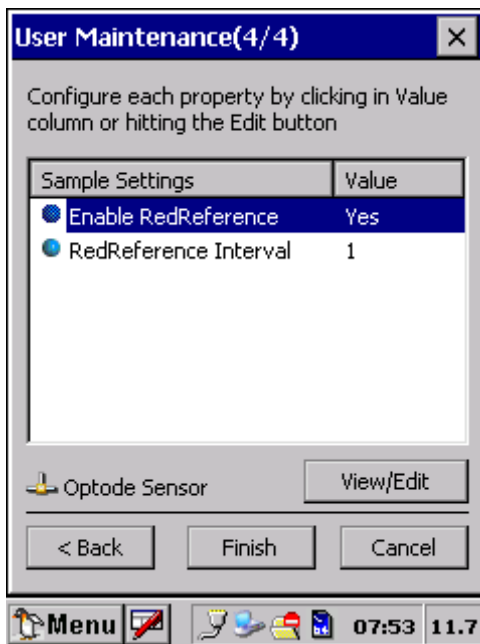

Figure 3 6 Enable RedReference

The last submenu in the Oxygen Optode user maintenance holds settings for:

- **Enable RedReference**; should normally be enabled (**Yes**). The phase measurements are then performed with a zero-point set at the red reference (no fluorescence). The property can be set to (**No**) in special measurement situations; contact AADI service department.
- **RedReference Interval**; this is a sample interval divisor for use of red reference. When the value is set to **1** (default) the red reference measurement is performed during each sample. The value can be increased to reduce power drain or to set a fast sampling interval, less than 2 sec. When the value is set to e.g. **10**, the red reference measurement is only performed for each 10th sample. Avoid setting the RedReference Interval too long compared to temperature changes in the sensor, as the RedReference is used to compensate for temperature drift in the electronics.

Procedure to change the property:

Select the output parameter from the list, press **View/Edit** in the lower part of the window, and change the setting. Press **Save** to store the setting when completed.

Press **Finish** to complete and exit and store the changes made in the Oxygen Optode User Maintenance. Selecting Cancel exits without storing your changes.

CHAPTER 4 Sensor configuration using Real-Time Collector

The sensors that are updated with Sensor Framework version 3 can be configured as stand-alone sensors using AADI Real-Time Collector.

Open the sensor connection as described in TD268 AADI Real-Time collector operating manual.

When the connection is established you can start and stop recordings or configure the device, refer Figure 4-1. Open Device Configuration and press Get Current Configuration. Check Include User Maintenance to view maintenance settings. The password is 1000.

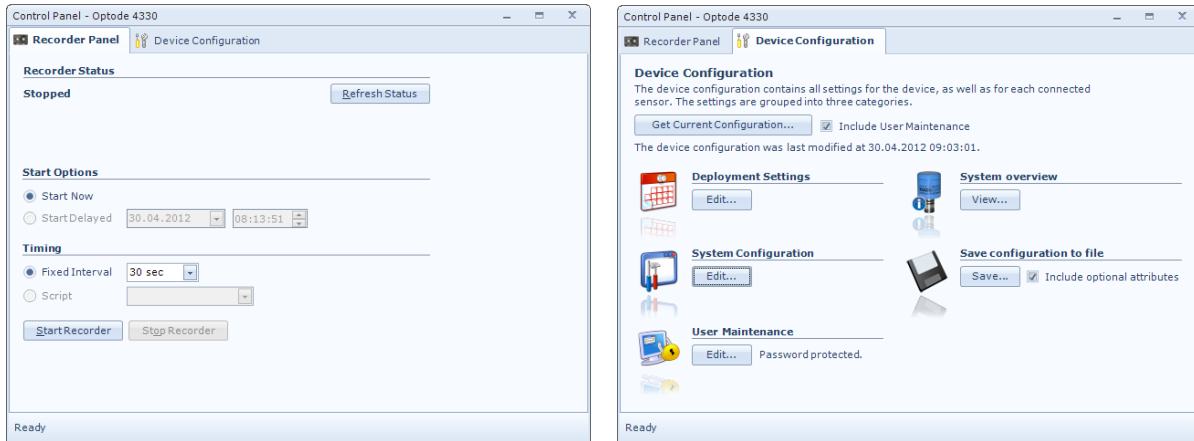

Figure 4-1 AADI Real-Time Collector screen views

User accessible sensor properties are found in Deployment settings, System Configuration and User Maintenance. Refer table Table 1-2 in chapter 1.2 for an overview of the properties. Refer chapter 5.7 for a description of sensor properties. To edit the configuration, click in the value-field and enter new value. Press **Next** to update sensor flash and store changes.

Figure 4-2, Figure 4-3 and Figure 4-4 presents screen views of AADI Real-Time Collector.

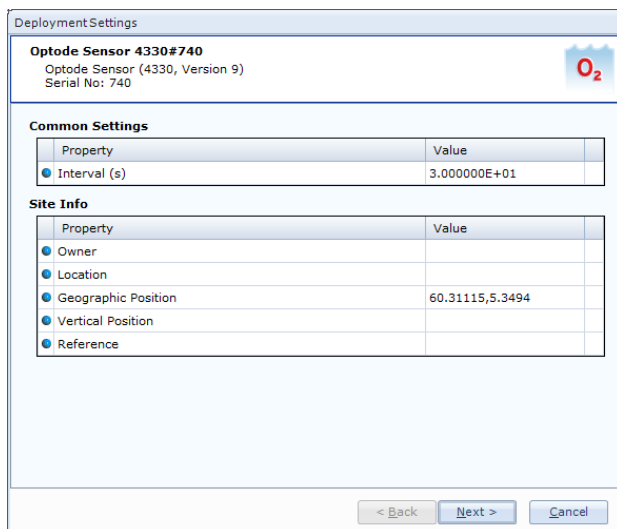

Figure 4-2 Sensor deployment settings

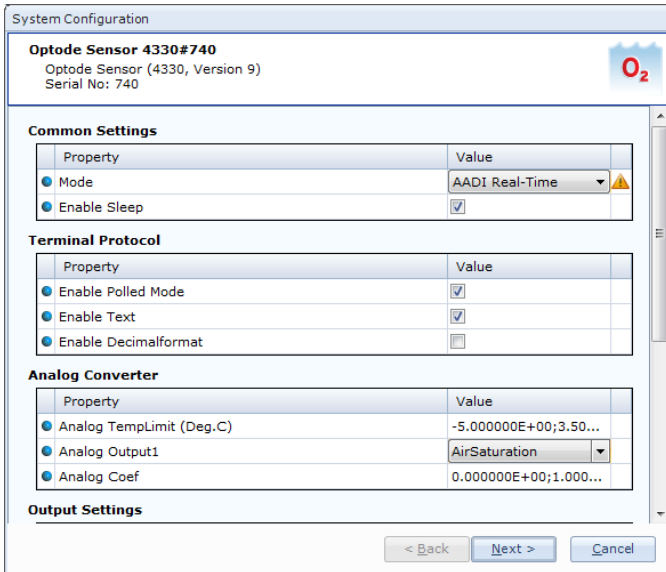

Figure 4-3 Sensor system configuration

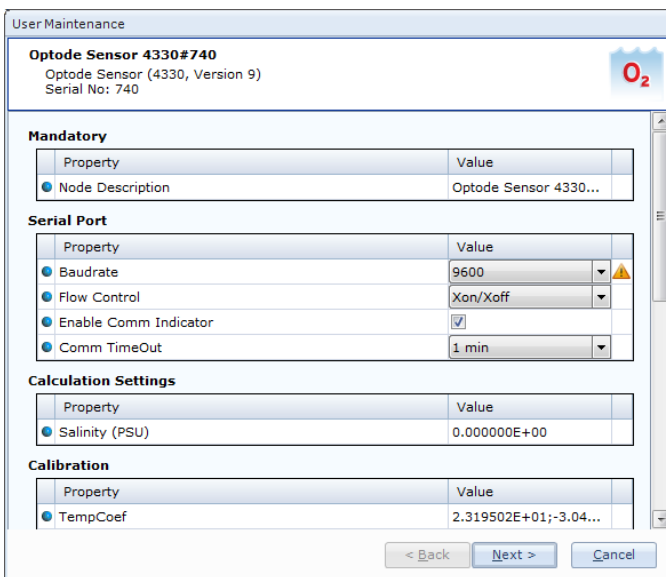

Figure 4-4 Sensor user maintenance

CHAPTER 5 Connection to PC

This chapter describes how to connect and communicate with the Oxygen Optode 4330, 4831 and 4835 using the RS232 protocol. Sensor configuration is described in chapter 5.7

Optional Sensor Cables: 3855 (1.5m) for laboratory use or Sensor Cable 4865 are used with 4330/4835 and cable 5335 with the 4831, refer Figure 5-1 and Figure 5-2, for the correct cable to be used for connection to the PC in the office/lab.

Note! The connector on Sensor Cable 3855 is made of Aluminium, due to risk of corrosion it is not recommended for use in saltwater. Same pin configuration as Cable 4865.

Either connect the additional USB plug in a USB port for providing power to the sensor (the USB port normally gives 5V power), or connect the USB plug to an included extension of the USB and connect to external power (5-14V), refer Figure 5-1.

Note! If power cannot be obtained from an USB port a practical solution is to use a 9V alkaline battery (6LF22) to set the sensor up or log it in the laboratory.

Sensor Cable 4865/5335 are also available in other lengths. The cable has a titanium plug, and can be used in applications that require a direct connection to a PC in RS232 operations.



Figure 5-1 Sensor Cable 3855.

See Appendix 8 for illustrations of all available cables.

5.1 RS232 Communication Setup

Most terminal programs can be used for RS232 communication with the sensor when connected to a PC, e.g. HyperTerminal[®] by Hilgraeve Inc (included in most Microsoft's operating systems). Other alternatives which can be downloaded from the Internet include Tera Terminal Pro.

For sensors with default configuration the following RS232 setup should be used:

9600 Baud

8 Data bits

1 Stop bit

No Parity

Xon/Xoff Flow Control

*) *Note! The options “Send line ends with line feeds” and “Echo line ends with line feeds” in the HyperTerminal ASCII setup must be selected.*

Note! If using Tera Terminal Pro, after setting up the com port according to settings above please select “Terminal” in the “Set up” menu and click “Local echo” also select “CR+LF” for both “Receive” and “Transmit” under “New line”.

Sensors with default configuration will start by presenting a start-up message when powered up. After that the sensor will perform a sample (depending on the configuration) and then enter a power down mode. The sensor can then be awakened by sending any character (Carriage Return, ‘/’ or ‘;’ is often preferred). By default the serial communication channel will then be active until 1 minute of inactivity at the serial input.

RS232 Smart Sensor Terminal protocol

All inputs to the sensor are given as commands with the following format:

- *MainCmd SubCmd* or *MainCmd Property(Value.., Value)*

Description of ASCII coded communication rules:

- The main command, *MainCmd*, is followed by an optional subcommand (*SubCmd*) or sensor property (*Property*).
- The *MainCmd* and the *SubCmd/Property* must be separated with the space ‘ ’ character.
- When entering new settings the *Property* is followed by parentheses containing comma-separated values.
- The command string must be terminated by Carriage Return and Line Feed (ASCII code 13 and 10).
- The command string is not case sensitive (UPPER/lower-case).
- A valid command string is acknowledged with the character ‘#’ while character ‘*’ indicates an error. Both are followed by Carriage Return/ Line Feed (CRLF). For most errors a short error message is also given subsequent to the error indicator.
- There are also special commands with short names and dedicated tasks, as *save*, *reset*, and *help*.

All names and numbers are separated by tabulator spacing (ASCII code 9).

The output string is terminated by Carriage Return and Line Feed (ASCII code 13 & 10).

5.2 Passkey for Write Protection

To avoid accidental change of the sensor configuration, most of the properties are write-protected. There are five levels of access protection, refer Table 5-1.

A special property called *Passkey* must be set according to the protection level before changing the value of properties that are write-protected, refer Table 1-2.

Table 5-1 Access protection levels

Output	Passkey	Description
No		No Passkey needed for changing property
Low	1	The Passkey must be set to 1 prior to changing property
High	1000	The Passkey must be set to 1000 prior to changing property This Passkey value also give read access to factory properties that usually are hidden
Read Only		The user have only read access, no passkey needed
Factory Write	XXXX	Sensor specific code for factory level access

5.3 Save and Reset

When the required properties are set, you must send a *Save* command to make sure that the new configuration are saved internally in the flash memory. The Oxygen Optode always reads the configuration from the internal flash memory after reset and power up.

When changing the *Mode* and *Baudrate* property a reset is required for the change to take effect. This can be done by recycling power or entering the Reset command. At start-up/reset the sensor normally presents a start-up information string as shown Figure 5-2.

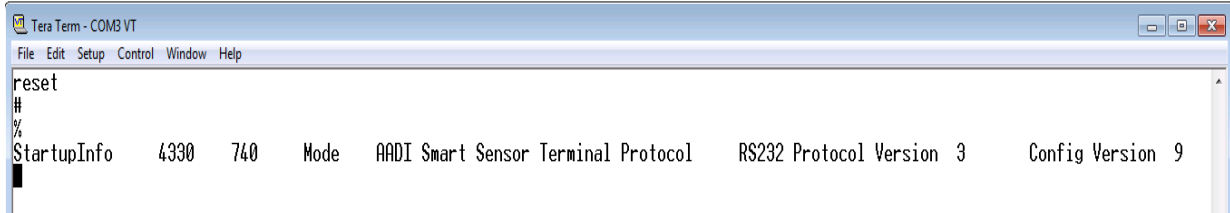

Figure 5-2 Sensor start-up/reset.

5.4 Communication Sleep

If the property *Comm TimeOut* is set to other than 'Always On' the serial interface will not be activated after power-up (or the Reset command). Any character will activate the serial interface, but a Carriage Return (CR or CR+LF), '/' or ';' are often preferred since these character do not interfere with the command syntax. The serial interface will then be active until a period of input inactivity specified by the *Comm TimeOut* value (10 s,20 s,30 s,1 min,2 min,5 min,10 min). The Communication Sleep Indicator, '%', will be transmitted when the serial communication is deactivated, and the Communication Ready Indicator, '!' is outputted subsequent to activation. When *Comm TimeOut* is set to 'Always On' the communication (and microprocessor) will be kept active all time.

The Communication Sleep Indicator '%' and the Communication Ready Indicator '!' are not followed by Carriage Return and Line Feed.

5.5 Available Commands for the Oxygen Optodes

Available commands and properties for the Oxygen Optode are given in Table 5-2 and Table 1-2 respectively.

Table 5-2 Main RS232 commands available for the Oxygen Optode.

Command	Description
Do Sample	Execute an oxygen measurement and presents the result
Start	Start a measurement sequence according to current configuration
Stop	Stop a measurement sequence
Do CollectCalDataSat ¹⁾	Collect and save calibration data for 100% saturation
Do CollectCalDataZero ¹⁾	Collect and save calibration data for 0% saturation
Do Calibrate ¹⁾	Execute a two point internal calibration function
Do Test	Internal use
Do AdjustGain	Optimize internal amplification to foil type, only used when changing between standard foil and fast response foil. Refer chapter 6.1 .
Get <i>ConfigXML</i>	Outputs info on available properties on XML format
Get <i>DataXML</i>	Outputs info on available(enabled) parameters on XML format
Get <i>Property</i>	Output Property value (refer Table 1-2)
Get All	Output all property values
Set <i>Property(Value,.. Value)</i>	Set Property to Value,... Value
Set <i>Passkey(Value)</i>	Set passkey to change access level
Save ¹⁾	Store current settings
Load	Reloads previous stored settings
Reset	Resets the sensor with new configuration
Help	Print help information
;	Comment string, following characters are ignored
//	Comment string, following characters are ignored

- 1) Note that the Save procedure might require up to 20 seconds. Losing power during this period will cause loss of latest configuration change. Wait for acknowledge, '#', before powering down the sensor. The save procedure is also executed when running the Do CollectCalDataSat, Do CollectCalDataZero and Do Calibrate –commands.

5.5.1 The Get Command

The *Get* command is used for reading the value/values of a property and for reading the latest value of a parameter.

The command name *Get* followed by a *Property* returns a string on following format:

```
Property ProductNo SerialNo Value, ..Value
```

The string starts with the name of the property, the product number and serial number of the sensor, and finally the value of the property, refer example in Figure 5-3.

The command name *Get* followed by a parameter returns the name and unit of the parameter, the product and serial number of the sensor, and finally the latest parameter reading, refer example in Figure 5-3.

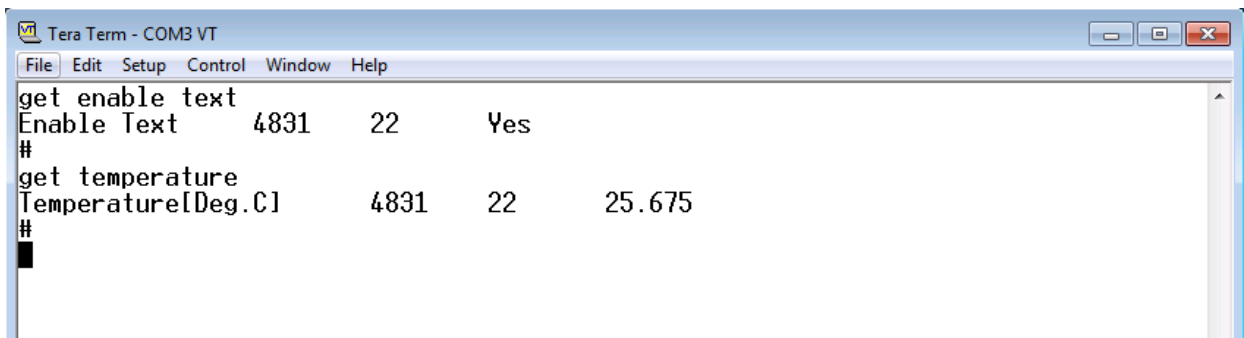

Figure 5-3 Examples of the Get command.

A special version, *Get All*, reads out all available properties in the sensor.

5.5.2 The Set Command

The *Set* command is used for changing a property. Type the corresponding *Get* command to verify the new setting, refer example in Figure 5-4.

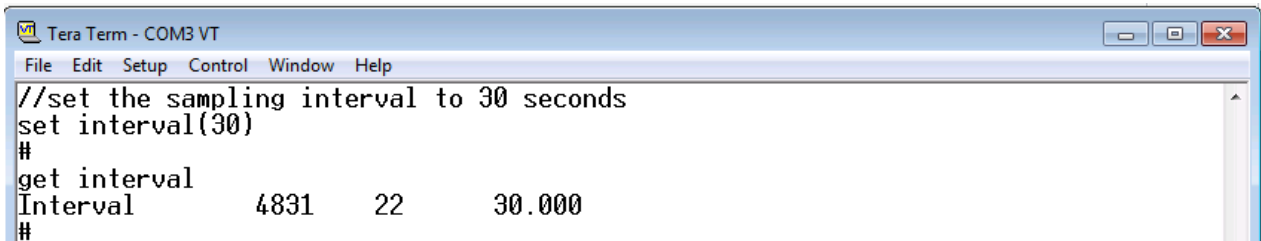
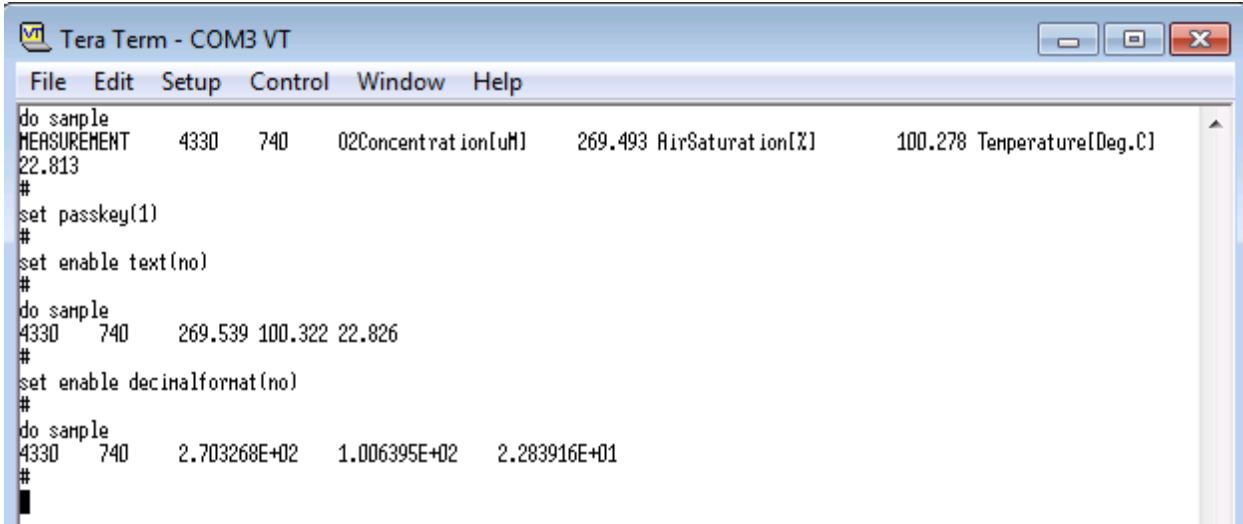

Figure 5-4 Example of the Set command.

Use the *Save* command to store the new property value. Some properties will require a *Reset* before the change is executed.

5.5.3 Formatting the Output String

The property called **Enable Text** controls the presentation of measured data. When the property is set to **(Yes)** the output string includes the descriptive parameter name. When the property is set to **(No)**, the output parameters are presented without descriptive parameter names; the parameter order is the same, refer Figure 5-5 for an example.



```
Tera Term - COM3 VT
File Edit Setup Control Window Help
do sample
MEASUREMENT 4330 740 O2Concentration[uM] 269.493 AirSaturation[%] 100.278 Temperature[Deg.C]
22.813
#
set passkey(1)
#
set enable text(no)
#
do sample
4330 740 269.539 100.322 22.826
#
set enable decimalformat(no)
#
do sample
4330 740 2.703268E+02 1.006395E+02 2.283916E+01
#
```

Figure 5-52 Example of output string: enable/disable text/decimal format

The property called **Enable DecimalFormat** controls the format of the output values, either as decimal numbers **(Yes)**, or in exponential format **(No)**. Refer **Figure 5-5**. for an example.

5.5.4 XML Commands

Get *ConfigXML* presents the configuration of all the sensor properties in XML format.

Get *DataXML* presents all of the enabled parameters in XML format.

5.6 Scripting -sending a string of commands

Often it may be usefully to collect more than one command in a text file. For example the instructions below can be written in an ordinary text editor and saved as a text file, which can be sent to the sensor. In HyperTerminal click *send text file* in the *Transfer* menu, and select the correct file. In Tera Terminal click "Send File" under "File" in main menu and select the file to be transferred.

Example of text file:

```
// Set sampling interval to 30 seconds  
Set Passkey(1)  
Set Interval(30)  
Save  
Get All
```

NOTE! The last line, Get All, reads out available properties for the sensor.

The first line is a comment line that is disregarded by the sensor. Strings starting with either ‘//’ or ‘;’ are ignored by the software, and do not produce errors or acknowledgements.

When sending text file the sensor can be awakened from sleep mode by sending a string of comment leads characters:

```
////////////////////////////////////  
////////////////////////////////////  
////////////////////////////////////  
// Wake up test  
Get All
```

This will provide time for the optode to wake up and be ready before the next string appears. Note that higher baud rates might require more lines of ‘/’ to provide sufficient delay. Communication wake up will normally require less than 100mS.

5.7 Sensor Configuration

The sensor configuration consists of sensor settings and customized presentation of data. Refer Table 1-2 for a list of all sensor properties and the input format; below follows a description of the properties that are typically set by the user prior to a deployment (RS232 application). Description of properties regarding the sensing foil and calibration are given in CHAPTER 6 .

The **Mode** property is used to set the operation mode. Available modes are AiCaP, Smart Sensor Terminal, AADI Real-Time and Analog Output.

- Set **Mode** to ‘**AiCaP**’ when connected to AADI SeaGuard or to a SmartGuard logger that automatically detects and recognices the sensor on CANbus(AiCaP).
- Set **Mode** to ‘**AADI Real-Time**’ for use with AADI Real-Time Data Collector or third party software that can handle XML based protocol
- Set **Mode** to ‘**Smart Sensor Terminal**’ for a simple ASCII command string based protocol when connected to PC or third party serial interface
- Set **Mode** to ‘**Analog Output**’ when interfacing 4330 or 4835 sensors to optional Analog 0-5 V, 4-20 mA adaptors.

Note! As default the 4330 and 4835 sensors are set to AiCaP communication while 4831 is set to Smart Sensor Terminal (RS232). Please select the correct Output according to which type of logger/interface you plan to use.

Set the **Enable AirSaturation**, **Enable Temperature**, and **Enable Rawdata** to (**Yes**) to include these parameters in the output string.

Set the **Enable Text** to (**Yes**) for the optode to output a detailed text string with the measurements, or (**No**) to output the measured values without the descriptive text.

Set the **Enable Decimalformat** to (**Yes**) to output the measured values in decimal format. Set the property to (**No**) to output the values in exponential format (higher resolution in the output parameter value).

The **Interval** property describes the measurement interval in seconds; the Optode provides a set of measured data for every measurement interval.

The **Salinity** property is set to 0 at the factory and the measurements must be post processed to compensate for the salinity variations at the measurement site. If the salinity is known at the site and relatively stable, you can set the Salinity property according to the known value and the measurements will be salinity compensated inside the sensor before presentation (useful for Real-Time measurements).

The **Enable HumidityComp** property describes compensation of vapour pressure in the calculations of the output parameters. **Enable HumidityComp** can be set to (**No**) if measurements are performed in complete dry conditions (dry air) or if you like to perform the humidity compensation as a post-processing operation. Measurements in dry conditions are more accurate when the **Enable HumidityComp** is set to (**No**). The property is set to (**Yes**) at the factory.

When **Enable Redreference** is set to (**Yes**), the phase measurements are performed with a zero-point set at the red reference (no fluorescence). The property can be set to (**No**) in special measurement situations; contact AADI service department. **Enable Redreference** is set to (**Yes**) at the factory before calibration; if the property is set to (**No**) the Optode must be recalibrated.

Set the **Enable Sleep** to (**Yes**) for the Optode to go to sleep between recordings, or (**No**) for the optode to stay continuously switched *on* between recordings (drains more power).

CHAPTER 6 Maintenance

The Oxygen Optode requires very little maintenance.

When the membranes on traditional oxygen consuming sensors (based on electrochemical principles), often called Clark sensors, are fouled the water mixing in front of the sensor membrane becomes poorer, which influences the measurement directly.

Since the Optode consumes no oxygen, the ability to diffuse gas has no influence on the measurement accuracy. However, if the fouling is in the form of algae that produce or consume oxygen, the measurement might not reflect the oxygen concentration in the surrounding water correctly.

Also the response time of the measurements might increase if the sensing foil is fouled. Therefore, the sensor should be cleaned at regular intervals depending on the fouling condition at the site.

Field experiences have demonstrated that AADI Optodes typically are a factor of 2-4 more fouling resistant than electrochemical oxygen sensors from other manufacturers and then the AADI conductivity sensors.

The Optode housing can be cleaned using a brush and clean water. Carefully, use a wet cloth to clean the sensing foil



Figure 6-1 Example of fouling on an RCM 9 with an Oxygen Optode 3830 (Optode version with SR-10 output) mounted to it: The Optode was still giving correct readings.

Fouling consisting of calcareous organisms (e.g. barnacles), can be dissolved by dipping the sensor/instrument in a weak acid solution (e.g. 7% Vinegar).

If the sensing foil is scratched or if the protective black layer on the foil is removed the sensor will still work as long as there is enough Fluorophore on the foil.

If severely damaged (so that the sensor gives unrealistic readings) the sensing foil must be replaced (Sensing Foil Kit) and the sensor recalibrated.

NOTE! Enter new calibration coefficients and perform a new two point calibration when changing the sensor foil.

The fluorescence life time measurement technology provides for very good long term stability. There is however a minor bleaching (break down) of the luminophore for every excitation of the foil. For the AADI Optodes this change is minimized by use of exceptional stable foil chemistry and careful excitation. Experience show that the foils have very good durability and generally become more stable over time. In figure 5-2 typical drift versus the number of excitations (samples) is depicted.

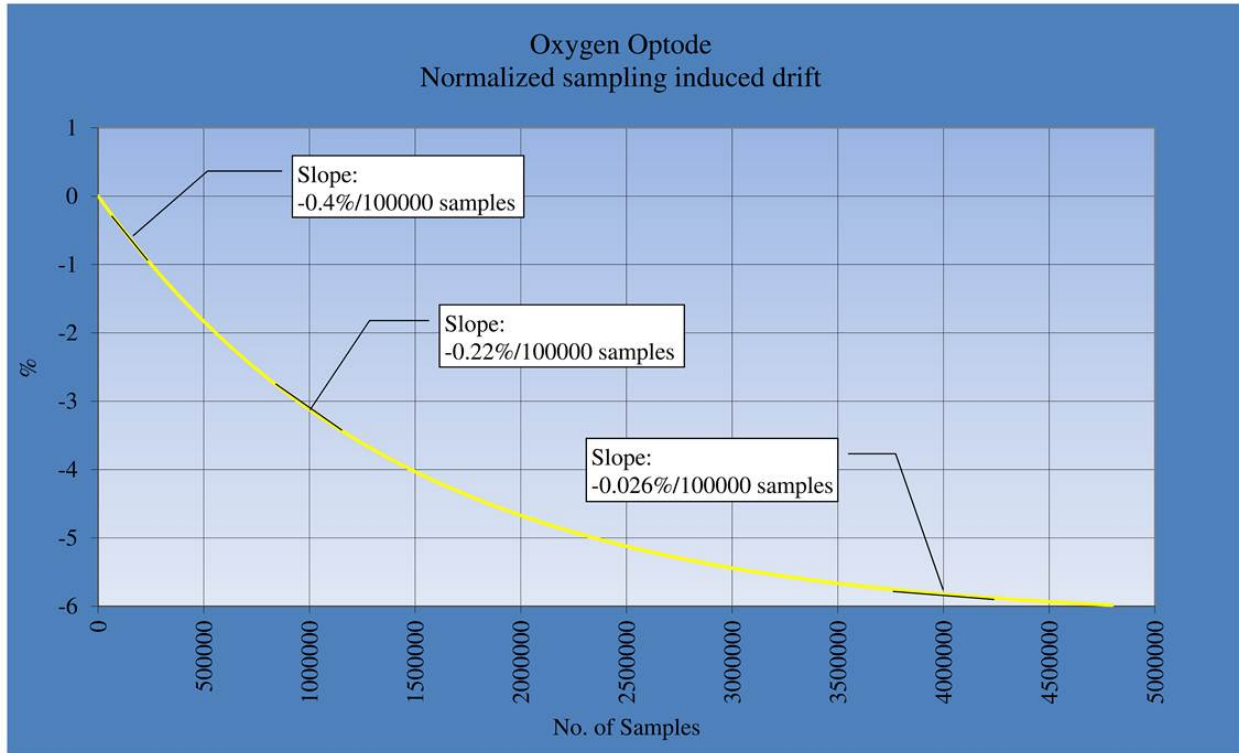

Figure 6-2 Normalized aging effect versus number of excitations

In order to maintain optimum accuracy it is recommended that user select the sampling frequency required for the application and to not over sample in order to minimize potential drift. Annual recalibration is optimal and recommended by the factory (refer next section) although for many applications this may not be possible. In case where longer calibration intervals are expected use of a controlled reference can be adequate to QC the data.

The standard foil is equipped with a black optical isolation layer to protect it from ambient light. The fast response foil is not equipped with this layer and is therefore more susceptible to bleaching from external light. While stored all foils and Optode must be shielded from ambient light. Optodes equipped with the fast response foil will normally require more frequent calibration but this is highly dependent on the amount of ambient light.

When saturated with moisture the polymer of the sensing foil will swell a little. This will cause a minor, approximately 2%, change in the response of the Optode. For optimum accuracy the foils should be wetted for 48 hours prior to use. The protecting cap supplied with the 4330 and 4831 style Optodes can be used for keeping the foil both wet and shielded from ambient light.

NOTE! It is not recommended to change standard foils (with the black isolation layer) unless they have serious mechanical damages. Faster response transparent foils can be bleached by light therefore these foils require greater care in handling and application. Indications for when you will need replace an otherwise undamaged foils are:

- Increasing levels of measurement noise
- TCPhase(deg) values below 10

AADI Service department can perform a cost-effective performance check and recalibration. Please fill out our Service Order Form, form no. 135, for this purpose (refer Services page at www.aanderaa.com)

6.1 Changing the Sensor Foil

If the sensor foil gets damaged it can easily be changed. For the 4330 and the 4831 models it is possible to change between the standard foil and fast response foil. The *Sensor Foil Kit 4733* for Optode 4330 and 4835 contains 2 standard foils while *Sensor Foil Kit 4794* for Optode 4330 and 4831 contains 2 fast response foils. The content of Kit 4733/4794 is given in Table 6-1, and a procedure for changing the foil is given below the table.

NOTE! If you use a foil from a different batch, new foil coefficients must be entered.

NOTE! After changing the foil and entering new foil coefficients a new two or multipoint calibration should be performed (see below).

Table 6-1 Contents of Sensor Foil Kit 4733/4794

Part no.	Pieces	Description	Foil Kit 4733	Foil Kit 4794
1206005C	2	Standard Sensing Foil packed in aluminium foil	X	
1206006	2	Fast Response Sensing Foil packed in aluminium foil		X
1913032	1	Torx key no. T10	X	X
1642223	2	M3 x 6mm screw torx a4 Din 965a (4330/4831)	X	X
1642222	2	M2.5 x 6mm screw torx a4 Din 965a (4835)	X	X
Form No. 721		Calibration Sheet for Sensing Foil (each batch of foils is calibrated)	X	X

6.1.1 Procedure for Oxygen Optode 4330 and 4831

Procedure for changing the sensor foil using kit 4733 or 4794:

- The sensor foil is changed by unscrewing the 4 torx screws in the securing plate, refer Figure 6-2. Remove the securing plate and the old foil.
 - Rinse clean the sapphire window with DI water
 - If the removed foil will be used in the future it should also be pre-cleaned and rinsed then packed in a light blocking package marked with the foil type and batch number.

o

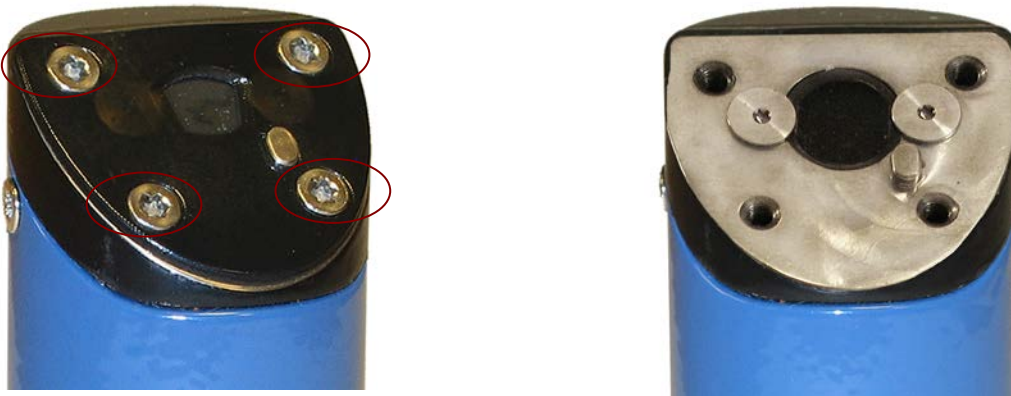

Figure 6-2 Removing the securing plate and change the sensing foil.

- Center the new foil to fit the optical window. It is important that the standard foil is mounted with the black side out, and the fast response foil with the *non-glossy* side out.
- Remount the securing plate.
- Figure 6-3). This should be done at room-temperature in air or saturated water. Ensure that the sensor is connected until the new amplification settings are stored (10-15 seconds)
- Control and if necessary update the sensing foil coefficients according to the foil certificate, refer chapter 0.
- Recalibrate the sensor, refer chapter 6.2.2.

```
Tera Term - COM3 VT
File Edit Setup Control Window Help
do adjustgain

Gain setting Adjusted to:
C1Gain      3      5      3      3      2      3      1      3      128  128  128  128
C2Gain      6      2      3      3      2      3      1      3      200  200  200  200
#
#O2Concentration[uM]  4330  740  2.649138E+02
#AirSaturation[%]    4330  740  9.856378E+01
#Temperature[Deg.C]  4330  740  2.280697E+01
#
```

Figure 6-3 Adjust Gain.

6.1.2 Procedure for Oxygen Optode 4835

Procedure for changing the sensor foil using kit 4733:

- The sensor foil is changed by unscrewing the 2 torx screws in the securing plate, refer Figure 6-2. Remove the securing plate and the old foil.
 - Rinse clean the sapphire window with DI water
 - If the removed foil will be used in the future it should be pre-cleaned and rinsed then packed in a light blocking package marked with the foil type and batch number.
- Center the new foil to fit the optical window. It is important that the standard foil is mounted with the black side out.
- Remount the securing plate.
- Control and if necessary update the sensing foil coefficients according to the foil certificate, refer chapters:3.2;4.1;5.1
- Recalibrate the sensor, refer chapter 6.2.2.



Figure 6-4 Removing the securing plate and change the sensing foil.

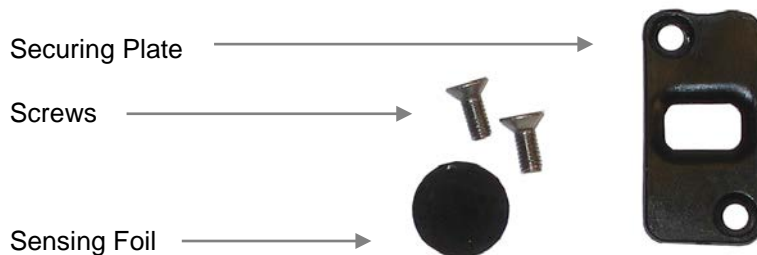

Figure 6-5 Illustration of parts, Optode 4835

6.2 Function Test

We recommend that you perform a function test of the sensor operating in air to verify the sensor readings. Refer chapter 6.2.1 and chapter 6.2.2. for a description of the function test procedure.

At sea level the oxygen saturation should be approximately 100% in air (90-110 %, depending on air pressure, local oxygen production/consumption and if the temperature sensor measurements are representative for the temperature of the foil). The saturation will be significantly lower when you breathe on or near the sensing foil.

The measured temperature should also agree with the ambient temperature.

6.2.1 SEAGUARD® Applications

Leave the Oxygen Optode 4330/4835 mounted onto the SEAGUARD® Platform. Power the instrument; refer TD262a and TD262b for operating instructions.

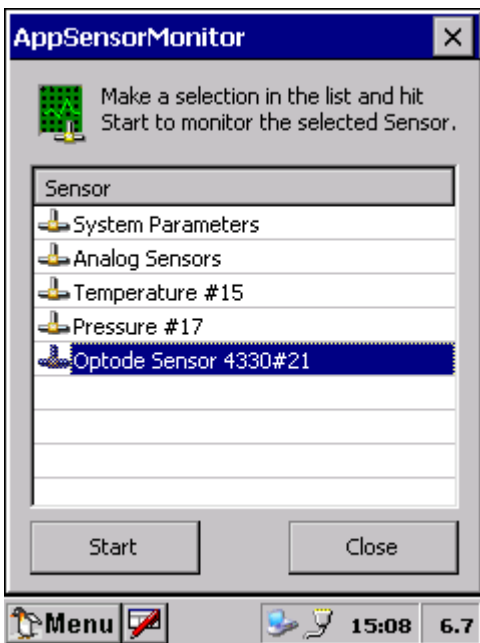

Open *Administrative Tools-> Sensor Monitor*

Sensor Monitor can be used as a direct reading of the sensor; the function is mainly used for test purposes.

Select the Optode from the list and press *Start*, refer Figure 6-6.

Figure 6-6 Select sensors to monitor

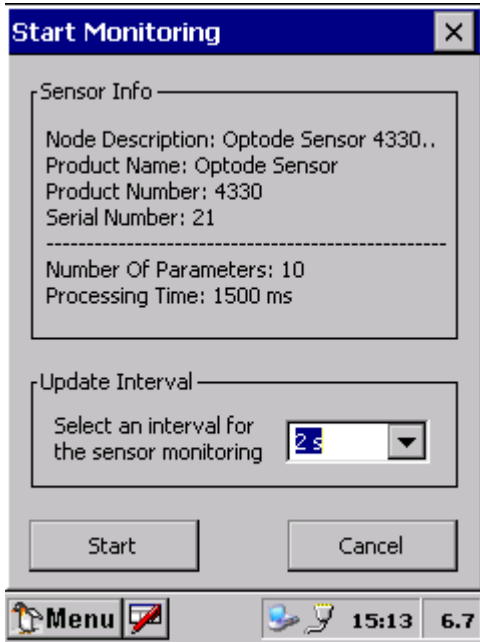

Figure 6-7 Set the Update Interval

The next window shows sensor information like the Node Description, Product name and number, and Serial number, refer Figure 6-7.

The number of sensor parameters and the processing time can be viewed in the window.

Select an *Update Interval* for the sensor monitoring. Press *Start* to start monitoring the sensor readings.

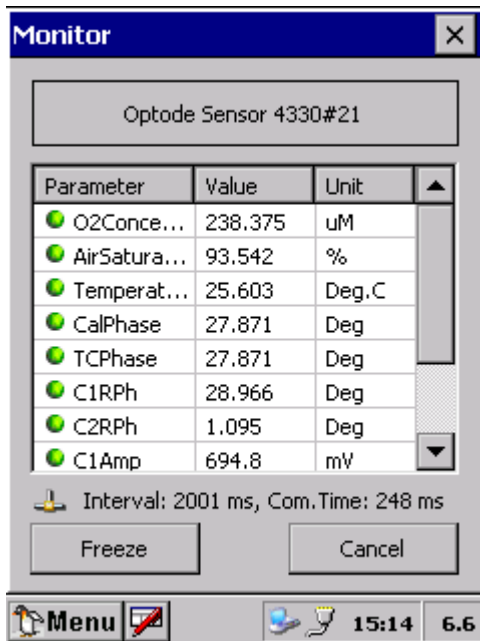

Figure 6-8 Monitor Sensor Readings

The parameter reading in engineering units is shown as illustrated in Figure 6-8. The reading updates according to the update interval.

Press *Freeze* to temporarily stop the update; press *Start* to restart monitoring (Start is the same button as Freeze).

Press *Cancel* to stop monitoring.

The sensor readings should be according to the description in chapter 6.2 .

Calibration

AADI has discovered that an after-curing occurs in the foils during the first 1-3 months after the foil was manufactured which typically leads to 1-4 % lower readings if the sensors are calibrated before the after-curing has stopped. As of today methods are in place to cure all foils before they are mounted on the Optodes and calibrated.

Each batch of sensing foils is delivered with calibration data describing the behaviour with respect to oxygen concentration and temperature. When changing the sensing foil the following 28 coefficients must be updated:

FoilCoeffA₀₋₁₃

FoilCoeffB₀₋₁₃

These coefficients are found in the Calibration Certificate for the Sensing Foil 3733/4793, refer enclosed documentation. Refer chapter 6.2.2 for changing foil coefficients.

In addition to the above mentioned coefficient update at a minimum a two point calibration must be done. This calibration compensates for individual sensor and foil variations.

Two controlled oxygen concentrations are relatively easy to obtain, one in air saturated water, and one in a zero-oxygen solution.

An air-saturated solution is obtained by inserting freshwater in a glass and bubble it with a standard aquarium pump. For a more efficient bubbling it is recommended to use an air stone bubble dispenser. The water should be allowed to achieve temperature stability for at least 1 hour. Take care to not have air bubbles on the foil. We recommend the zero oxygen solution to be obtained by preparing another glass of the same water (as for air saturation) and dissolving 5g of sodium sulphite (Na₂SO₃) in 500ml water.

6.2.2 Calibration Procedure using a Terminal Program

NOTE! To obtain the highest accuracy the sensor(s) to be calibrated should be submerged into water at least 24-48 hours prior to the calibration. If a sensor is allowed to dry out this could lead to a bias in the readings of up to 2 %. This effect disappears when the sensor is submerged into the water.

Prepare a suitable container with freshwater. Aerate (apply bubbling) to the water using an ordinary aquarium pump together with an air stone, and let the temperature stabilize (might take hours).

Prepare a zero oxygen solution by dissolving 5 grams of sodium sulphite (Na₂SO₃) in 500 ml of water. Other substances that remove oxygen can also be used.

NOTE! Stripping of the oxygen with e.g. N₂ gas is also possible, but not recommended, since it is uncertain when and if ever an absolute zero oxygen level is/can be reached using this method.

Connect the sensor to a PC by use of the Sensor Cable 3855 (see above RS232 communication).

Start a terminal program, i.e. the HyperTerminal by Hilgraeve Inc (included in Microsoft operating systems) or Tera Terminal with the following set-up:

9600 Baud

8 Data bits

1 Stop bit

No Parity

Xon/Xoff Flow Control

NOTE! Select one of the options 'Sent line ends with line feeds' or 'Echo line ends with line feeds' in the Hyper Terminal.

Note! If using Tera Terminal Pro, after setting up the com port according to settings above please select "Terminal" in the "Set up" menu and click "Local echo" also select "CR+LF" for both "Receive" and "Transmit" under "New line".

Control, and if necessary update, the *FoillD*, *FoilCoefA*, *FoilCoefB*, *FoilPolyDegT*, *FoilPolyDegO* properties accordingly to the Calibration Certificate for the sensing foil in use (refer CHAPTER 5 for communication with the sensor).

Example of changing foil coefficients:

```
Set Passkey(1000)
Set FoillD(1707)
Set FoilCoefA(1.71404376E-04,3.04290906E-04,-6.39414910E-02,5.14270106E+00,-
2.84638794E-02,3.88090809E-05,-1.92200149E+02,1.66135018E+00,-5.18448297E-
03,1.22642972E-05,2.89178945E+03,-3.48247963E+01,2.03067907E-01,-1.72740886E-03)
Set FoilCoefB(1.23230336E-05,0,0,0,0,0,0,0,0,0,0,0,0,0,0,0)
Set FoilPolyDegT(1,0,0,0,1,2,0,1,2,3,0,1,2,3,4,0,0,0,0,0,0,0,0,0,0,0,0)
Set FoilPolyDegO(3,4,3,2,2,2,1,1,1,1,0,0,0,0,0,0,0,0,0,0,0,0,0,0,0,0)
Save
```

Type *Get All* to verify the new coefficients.

Script files for entering the foil coefficients via text terminal programs will be available from the factory.

1. Submerge the Optode into the aerated water. Set the *Interval* property to e.g. 30 seconds. Enter the *save* command and wait until both the temperature and the phase measurements have stabilized:

```
Set Passkey(1000)
Set Interval(30)
Save
```

2. Store calibration values by typing:

```
Set Passkey(1000)
Do CollectCalDataSat
```

The *save* command is automatically performed when you type *Do CollectCalDataSat*.

3. Set the *CalDataAPress* property to the actual air pressure in hPa at the site.

```
Set Passkey(1000)
Set CalDataAPress (..)
Save
```

NOTE! For maximum accuracy do not compensate the air pressure for height above sea level.

Submerge the Optode in the zero solution. **Make sure that the sensing foil is free from air bubbles.** Wait until both the temperature and the phase measurements have stabilized.

4. Enter the `Do CollectCalDataZero` command to store calibration values. The `save` command is automatically performed.

`Set Passkey(1000)`
`Do CollectCalDataZero`

5. Enter the `Do Calibrate` command to effectuate the new calibration and store the new coefficients in the sensor memory. The `save` command is automatically performed.

`Set Passkey(1000)`
`Do Calibrate`

Check that the sensor is working properly by taking it up into the air and rinse off, flush the sensor well to remove all of the Zero Oxygen water to not have cross contamination of your saturated sample. In dry air, the sensor should show close to 100% oxygen saturation at sea level. Put the sensor back into the anoxic water; the reading should drop to zero.

Appendix 1 Theory of Operation

The Oxygen Optode is based on a principle called dynamic luminescence quenching.

This phenomenon is the ability of certain molecules to influence the fluorescence of other molecules. Fluorescence is the ability of a molecule to absorb light of certain energy and later emit light with lower energy (longer wave length). Such a molecule, called a luminophore, will after absorbing a photon with high enough energy, enter an excited state.

After a while the luminophore will emit a photon of lower energy and return to its initial state. Some types of luminophores might also return to the initial state when colliding with certain other molecules.

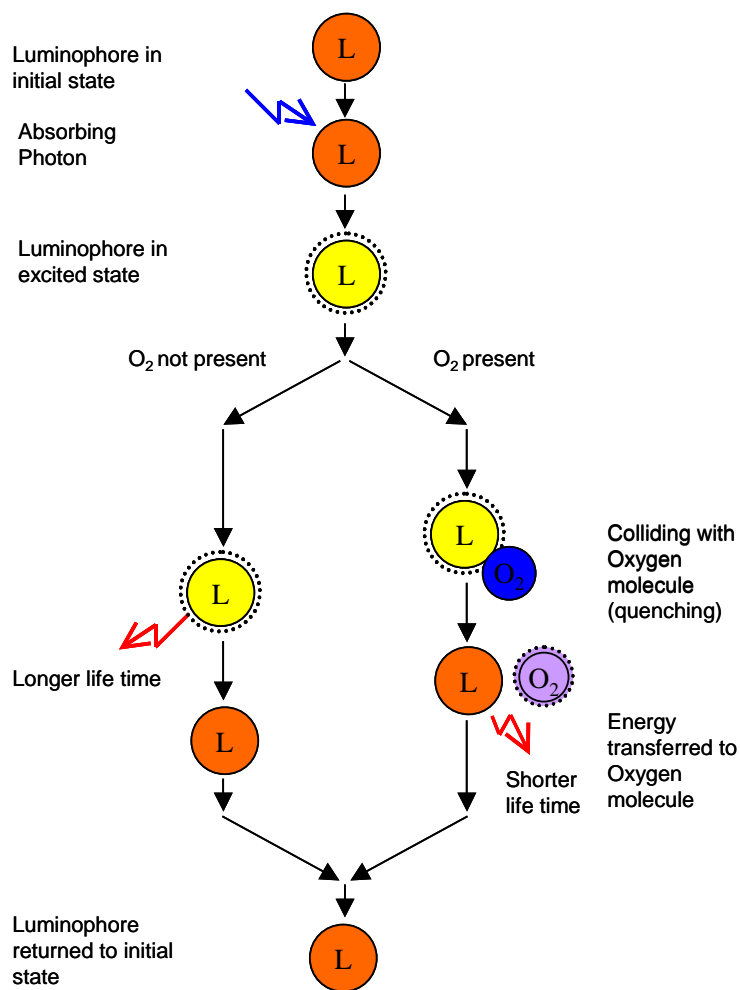

Figure A 1 Dynamic Luminescence Quenching

The luminophore will then transfer parts of its excitation energy to the colliding molecule, with the result that less photons (giving a shorter life time) are emitted from the luminophore. This effect is called dynamic luminescence quenching, and in the Oxygen Optode the colliding molecules are O_2 .

The luminophore used in the Oxygen Optode is a special molecule called platinum porphyrine. These luminophores are embedded in a polymer layer, called the indicator layer (coated on a thin film of polyester support).

To avoid potential influence from fluorescent material surrounding the sensor or direct incoming sunlight when measuring in the photic zone, the normal monitoring foil is also equipped with a black gas permeable coating.

The coating gives optical isolation between the indicator layer and the surroundings. For faster response time foils also exist without the optical isolation layer, transparent foils, through which the blinking blue and red light can be seen. The transparent foils are only available for 4330 and 4831 optodes.

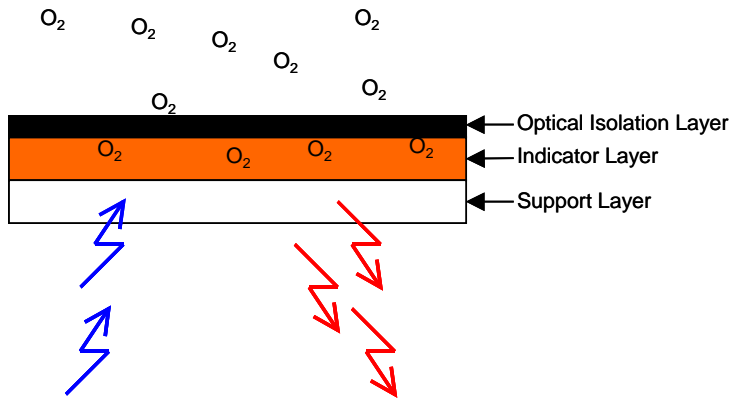

Figure A 2 Sensing Foil

Luminescence Decay Time

Due to its fluorescent behaviour the sensing foil will return a red light when it is excited with a blue-green light (505 nm). If there is O_2 present this fluorescent effect will be quenched.

The amount of returned light will therefore depend on the O_2 concentration in the foil.

The intensity of the returned light is however not the optimal property to measure since it depends on many other factors as i.e. optical coupling or bleaching of the foil.

Since the returned light is delayed with respect to the excitation light, the presence of O_2 will also influence the delay.

This property is called luminescence decay time (or lifetime) and it will decrease with increasing O_2 concentrations.

The relationship between the O₂ concentration and the luminescence decay time can be described by the Stern-Volmer equation:⁴

$$[O_2] = \frac{1}{K_{SV}} \left\{ \frac{\tau_0}{\tau} - 1 \right\}$$

where:

τ = decay time

τ_0 = decay time in the absence of O₂

K_{SV} = Stern-Volmer constant (the quenching efficiency)

In order to measure this luminescence decay time, the sensing foil is excited with a blue-green light modulated at 5 kHz.

The decay time is a function of the phase of the received signal.

In the Oxygen Optode the relationship between the phase and the O₂-concentration is used directly, without calculating the decay time.

Figure A 3 shows a typical relationship between the phase measurement and O₂ concentration.

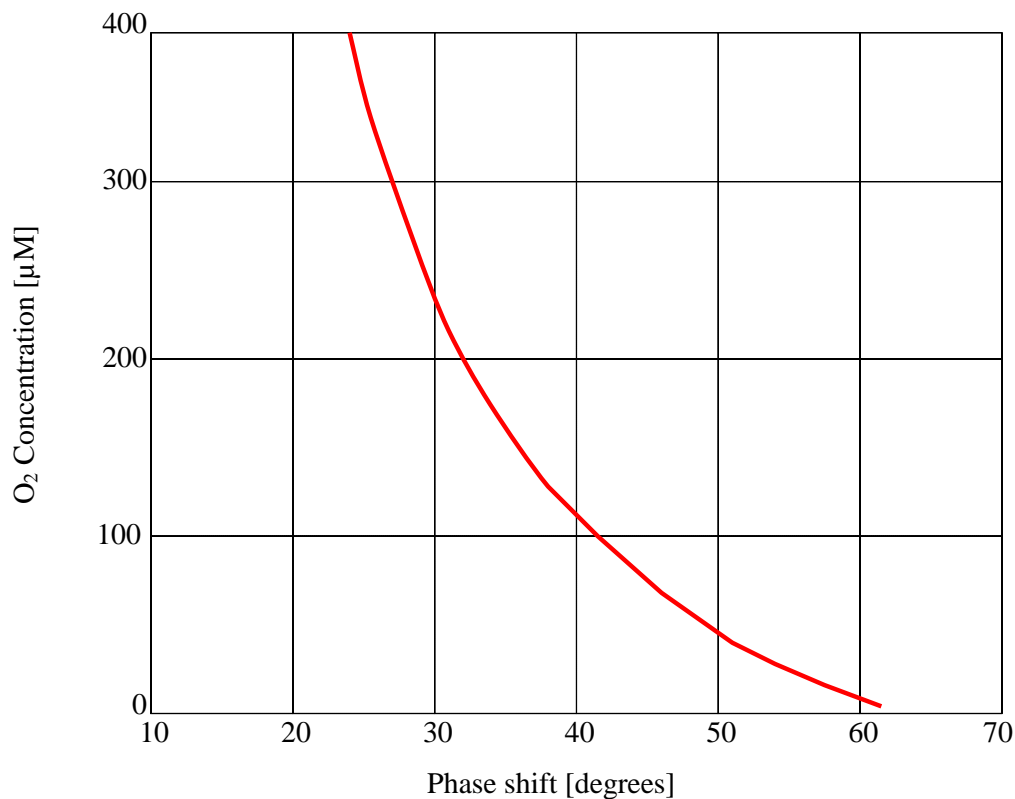

Figure A 3 Typical Phase/O₂ response

Appendix 2 The Optical Design

An illustration of the optical design is given in Figure A 4.

The sensing foil is mounted outside the optical window and is exposed to the surrounding water. The foil is held in place by a screw fixed plastic plate.

Two light emitting diodes (LEDs) and one photodiode are placed on the inside of the window. A blue-green LED is used for excitation of the foil. The photodiode is used for sensing the fluorescent light.

Even though the sensing foil is highly fluorescent parts of the transmitted light will be directly reflected.

The photo diode is equipped with a colour filter that stops light with short wavelengths to minimize the influence of the reflected light. Further, the blue-green LED is equipped with a filter that stops light with long wavelengths.

In addition, a red 'reference' LED is included to compensate for potential drift in the electronics of the transmitter and receiver circuit.

The spectral response of the LEDs and the filter are illustrated in Figure A 5.

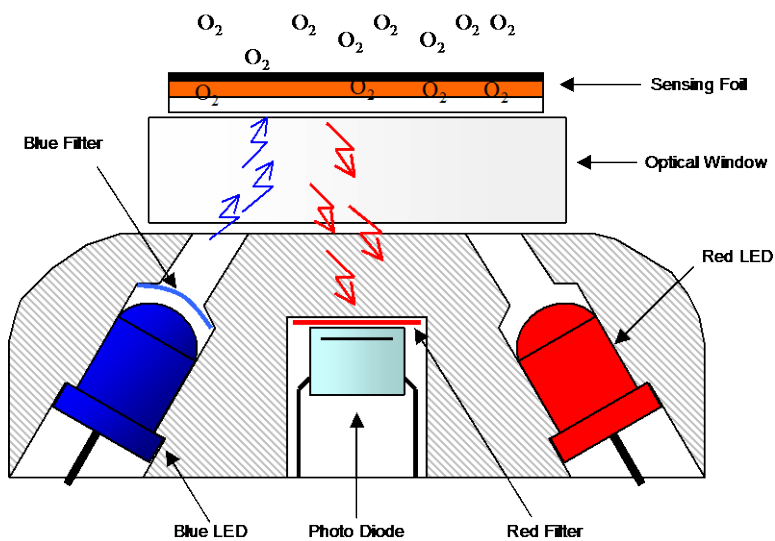

Figure A 4 The Optical Design

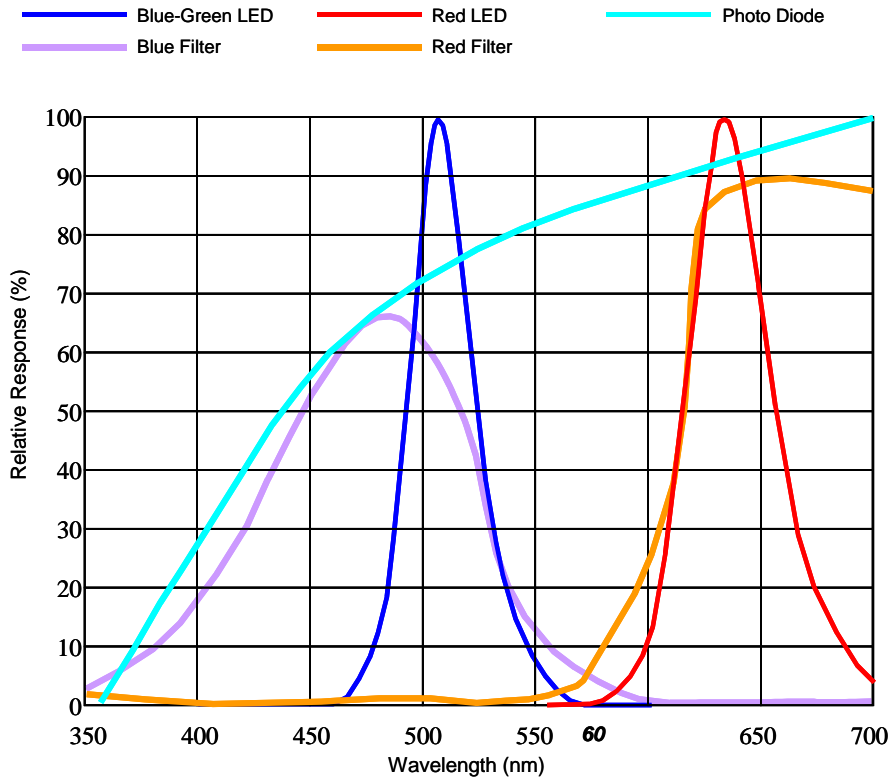

Figure A 5 An example of Spectral Response

Appendix 3 Electronic Design

Figure A 6 illustrates the main functions of the electronics.

To obtain good oxygen measurements the electronic circuit must be able to measure the phase between the excitation signal and the received signal accurately and with good resolution.

The received signal is sampled with a frequency of four times the excitation frequency. Two signal components with a phase difference of 90 degrees are extracted from these samples and are used for calculations of the phase of the received signal.

The O₂-concentration is calculated after linearizing and temperature compensating the phase measurements.

A thermistor thermally connected to the sensor body, provides temperature measurements.

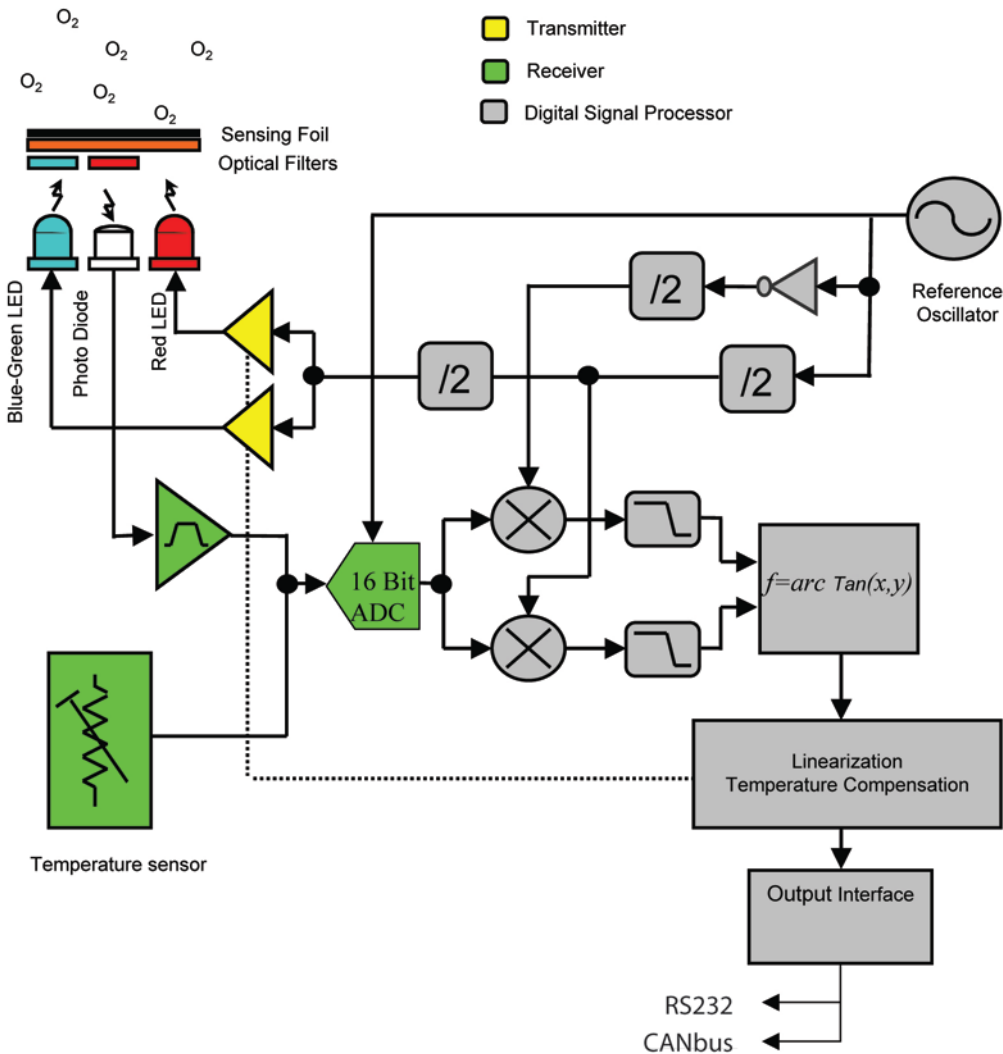

Figure A 6 Functional Diagram

Appendix 4 Mechanical Design of Optode 4330 and 4831

Refer Figure 1-1 and 1-2 and Figure A 7 and A8 for illustration of the Oxygen Optode 4330.

A cylindrical titanium housing shields the electronics from the surrounding water and high pressure (pressure resistance for standard sensor is 6000 m. These sensors do also exist in a special 12 000 m rated version).

A 4mm thick sapphire window provides the optical connection between the optics inside the Optode and the sensing foil on the outside.

The foil is fixed to the window by a POM securing plate and is easily replaceable.

For the 4330 a 10-pin receptacle in the sensor foot provides all electrical connection to the sensor.

To prevent potential leakage from the sensor to the rest of the measurement system, the receptacle is moulded inside a receptacle housing.

For the 4831 the receptacle is an 8 pin Subconn **MCBH8M** wet-mate connector.

Note! The sensor should not be opened! Opening the sensor housing can breach the warranty (ref. CHAPTER 6 , page 37 for instructions on how to change the Sensing Foil).

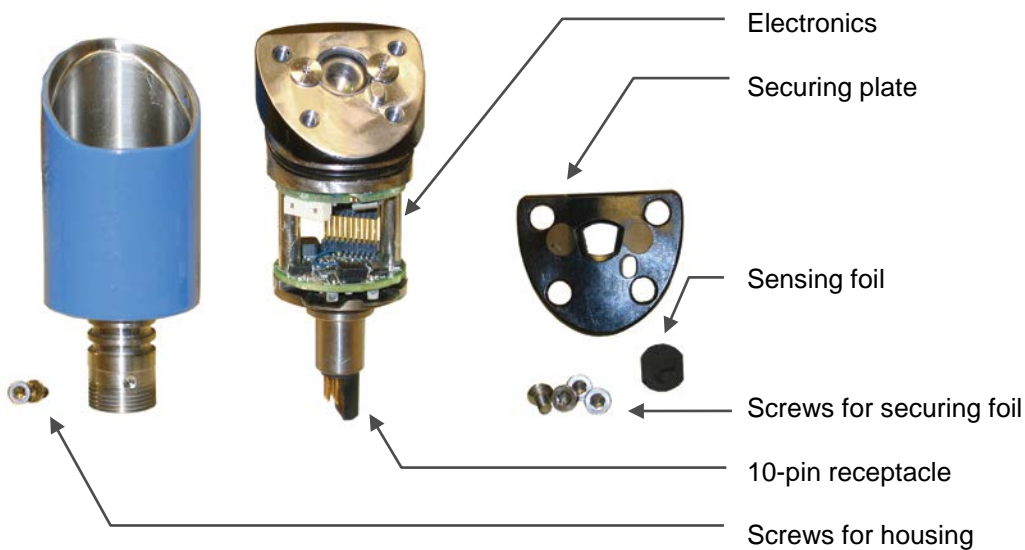

Figure A 7 Oxygen Optode 4330 components.

Appendix 5 Mechanical Design of Optode 4835

Refer Figure 1-3 and Figure A 8 for illustration of the Oxygen Optode 4835. A cylindrical polymer housing shields the electronics from the surrounding water (pressure rated to 300 m).

A 4mm thick sapphire window provides the optical connection between the optics inside the Optode and the sensing foil on the outside. The foil is fixed to the window by a POM securing plate and is easily replaceable.

A 10-pin receptacle in the sensor foot provides all electrical connection to the sensor. To prevent potential leakage from the sensor to the rest of the measurement system, the receptacle is moulded inside a receptacle housing.

Refer CHAPTER 6 for instructions concerning changing the Sensing Foil.

Note! The sensor should not be opened! Opening the sensor housing can breach the warranty (ref. CHAPTER 6 , page 39 for instructions on how to change the Sensing Foil).

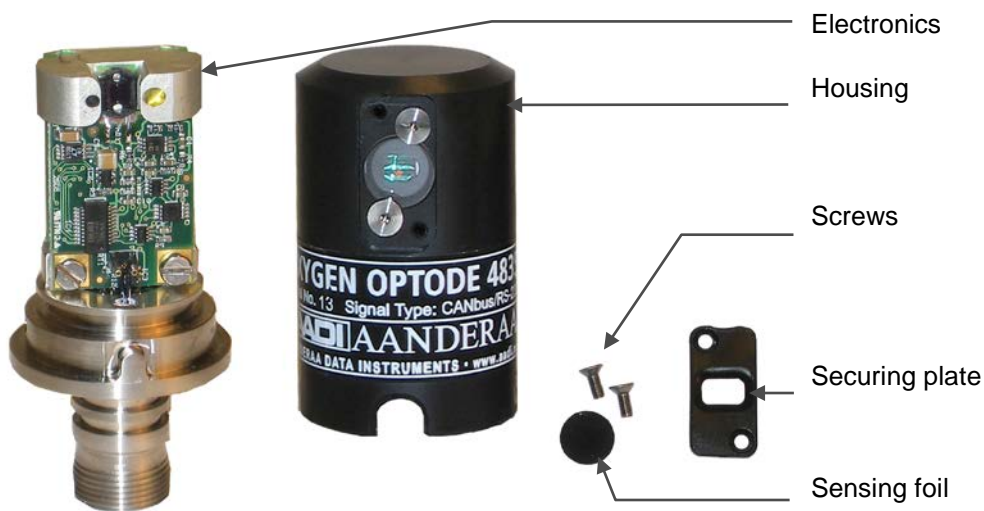

Figure A 8 Oxygen Optode 4835 components.

Appendix 6 Primer –Oxygen Calculations in the Sensor

The Optode normally excites the foil with both blue and red light. Since the red light does not produce any fluorescence in the sensing foil the phase obtained in this measurement is used as a reference in the system. After collecting the raw data the difference between the phase obtained with blue (C1Phase) and red light (C2Phase) excitation is calculated as:

$$TPhase = A(t) + (C1Phase - C2Phase) \cdot B(t)$$

The A(t) and B(t) are 3rd order temperature dependent polynomials that provides for a possibility for temperature compensation of the phase measurement. Normally this option is not used and A(t)=0, B(t)=1. Coefficients for A and B are held in the properties called PTC0Coef and PTC1Coef respectively.

Subsequently the CalPhase is calculated as:

$$CalPhase = PhaseCoef_0 + PhaseCoef_1 \cdot TPhase + PhaseCoef_2 \cdot TPhase^2 + PhaseCoef_3 \cdot TPhase^3$$

For older Optodes (serial number less than 1000) the first two coefficients were adjusted during a 2-point calibration. For newer optodes this function is normally not in use (i.e. $PhaseCoef_0=0$, $PhaseCoef_1=0$, $PhaseCoef_2=0$, $PhaseCoef_3=0$).

The temperature in °C is calculated from raw data (RawTemp) by use of a polynomial similar to the above with coefficients stored in the TempCoef property.

Based on the calibrated phase (CalPhase) and temperature (Temperature) the partial pressure of O₂ is calculated by use of a two dimensional polynomial:

$$\Delta p = C_0 \cdot t^{m_0} \cdot ph^{n_0} + C_1 \cdot t^{m_1} \cdot ph^{n_1} + C_2 \cdot t^{m_2} \cdot ph^{n_2} + \dots + C_{27} \cdot t^{m_{27}} \cdot ph^{n_{27}}$$

where the polynomial coefficients C₀ to C₁₃ are stored in the property *FoilCoefA* and C₁₄ to C₂₇ are stored in *FoilCoefB*. The temperature exponents, m_{0..27}, are stored as *FoilPolyDegT* and phase exponents, n_{0..27}, are stored as *FoilPolyDegO*.

From the partial pressure the air saturation is then calculated as:

$$AirSaturation(\%) = \frac{\Delta p \cdot 100}{[NomAirPress - p_{vapour}(t)] \cdot NomAirMix}$$

where *NomAirPress* is a property for the nominal air pressure, usually 1013.25 hPa, and *NomAirMix* is the nominal O₂ content in air, by default 0.20946.

The $p_{vapour}(t)$ is the vapour pressure calculated from temperature by the following equation:

$$p_{vapour}(t) = e^{\left(52.57 - \frac{6690.9}{t+273.15} - 4.681 \cdot \ln(t+273.15) \right)}$$

If the property *Enable HumidityComp* is set 'No' the $p_{vapour}(t)$ will be set to zero.

The oxygen concentration is finally calculated as:

$$O_2\text{Concentration}(\mu\text{M}) = \frac{C^* \cdot 44.614 \cdot \text{AirSaturation}}{100}$$

where C^* is the oxygen solubility (cm^3/dm^3) calculated from the Garcia and Gordon equation of 1992:

$$\ln(C^*) = A_0 + A_1T_s + A_2T_s^2 + A_3T_s^3 + A_4T_s^4 + A_5T_s^5 + S(B_0 + B_1T_s + B_2T_s^2 + B_3T_s^3) + C_0S^2$$

where:

T_s = scaled temperature

$$= \ln \left[\frac{298.15 - t}{273.15 + t} \right]$$

t = Temperature, °C

S = Salinity (configurable property, default set to zero)

$A_0 = 2.00856$	$B_0 = -6.24097\text{e-}3$
$A_1 = 3.22400$	$B_1 = -6.93498\text{e-}3$
$A_2 = 3.99063$	$B_2 = -6.90358\text{e-}3$
$A_3 = 4.80299$	$B_3 = -4.29155\text{e-}3$
$A_4 = 9.78188\text{e-}1$	$C_0 = -3.11680\text{e-}7$
$A_5 = 1.71069$	

By nature the relationship between the phase shift and oxygen concentration should follow Stern-Volmer relationship. The above formula is a general two dimensional polynomial with a flexible degree and was introduced since the basic Stern-Volmer did not provide satisfactory curve fit. In Uchida et al., 2008 a modified Stern-Volmer function was suggested:

$$[O_2]' = \frac{\left(\frac{P_0}{P_c} - 1\right)}{K_{SV}}$$

and:

$$K_{SV} = c_0 + c_1t + c_1t^2$$

$$P_0 = c_3 + c_4t$$

$$P_c = c_5 + c_6P_r$$

where t is temperature (°C) and P_r is the raw phase shift reading (CalPhase)

Later it has been shown by Craig Neill (CSIRO) that this formula generally performs better with respect to interpolation between calibration points and extrapolation outside the calibration range. Based on this and recommendation from the Argo oxygen meeting in Brest 2011 the above formula has been implemented in the Optode firmware (serial no. 1000 and above).

In order to use the “Stern-Volmer-Uchida” formula the property called *Enable SVUformula* must be set to ‘yes’. The coefficients c_0 to c_6 are stored in the *SVUFoilCoef* property.

A possibility for linear correction of the O_2 concentration was also introduced:

$$\mathbf{O2Concentration[uM]} = \mathbf{ConcCoef_0} + \mathbf{ConcCoef_1[O_2]}'$$

For new Optodes (serial no. 1000 and above) the two-point calibration procedure (ref Calibration Procedure chapter 6.2.2) will adjust the *ConcCoef* coefficients.

Appendix 7 Multipoint Calibration

The standard calibration for the oxygen Optodes is based on a common characterization of a production batch of sensing foils with an additional two-point adjustment for individual Optodes and foils.

For application demanding higher accuracy an individual multipoint calibration is available. The Optodes are then placed in a temperature regulated bath where the oxygen saturation is changed by diffusing different mixtures of O₂ and N₂ into the water. The gas mixture is controlled by use of high accuracy Mass Flow Controllers. The water is stirred vigorously to provide homogeneity and oxygen concentration is referenced to three reference sensors that are calibrated with respect to high quality Winkler titrations. For a standard multipoint calibration the oxygen is changed from 0 to 120% air saturation in 10 steps, and temperature from 1 to 30 °C in 4 steps, resulting in 40 individual calibration points. Based on these data 7 coefficients (c₀ to c₆) in the modified Stern-Volmer formula derived by Uchida et al, 2008 [17] is calculated:

$$[O_2]' = \frac{\left(\frac{P_0}{P_c} - 1\right)}{K_{SV}}$$

and:

$$K_{SV} = c_0 + c_1 t + c_2 t^2$$

$$P_0 = c_3 + c_4 t$$

$$P_c = c_5 + c_6 P_r$$

where t is temperature (°C) and P_r is the raw phase shift reading (CalPhase)

After the calibration sequence the performance of all sensors are verified in 20 points covering the complete calibration range.

Note that the multipoint calibration is only available for the 4330 and 4831 Optode and that in order to enable of use of the above formula the property called *Enable SVUformula* must be set to “yes” (requires firmware version 4.4.8 or higher).

Appendix 8 Illustrations

Figure no.	Description
Figure A 9	Drawing Cable 4865.
Figure A 10	Drawing Cable 3855.
Figure A 11	Drawing Cable 5335.
Figure A 12	Drawing Cable 4762.
Figure A 13	Drawing Cable 4793.
Figure A 14	Drawing Cable 5335
Figure A 15	Drawing Cable 5336
Figure A 16	Drawing Cable 5280

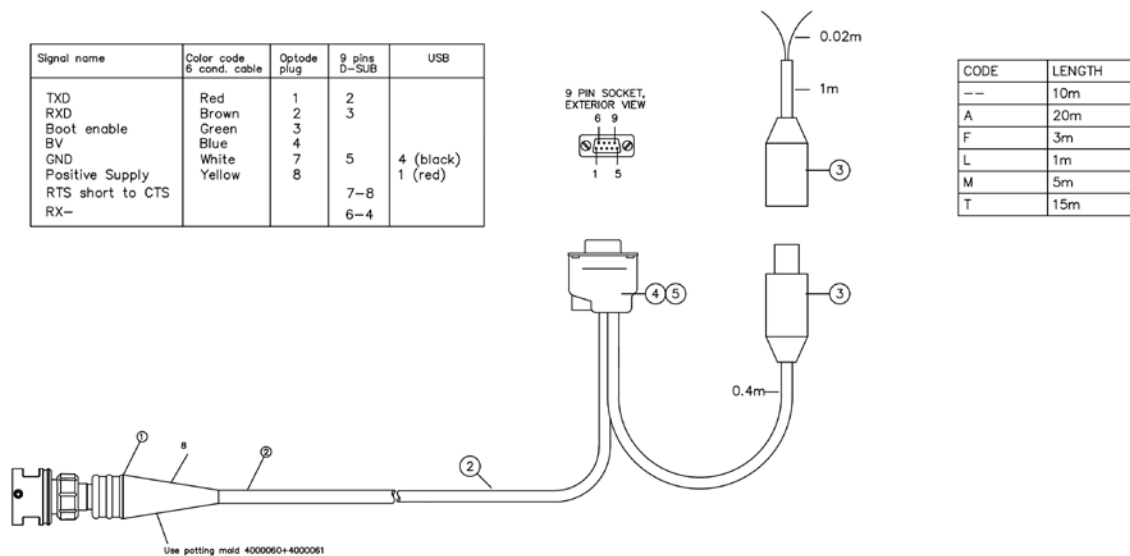

Figure A 9 Drawing Cable 4865.

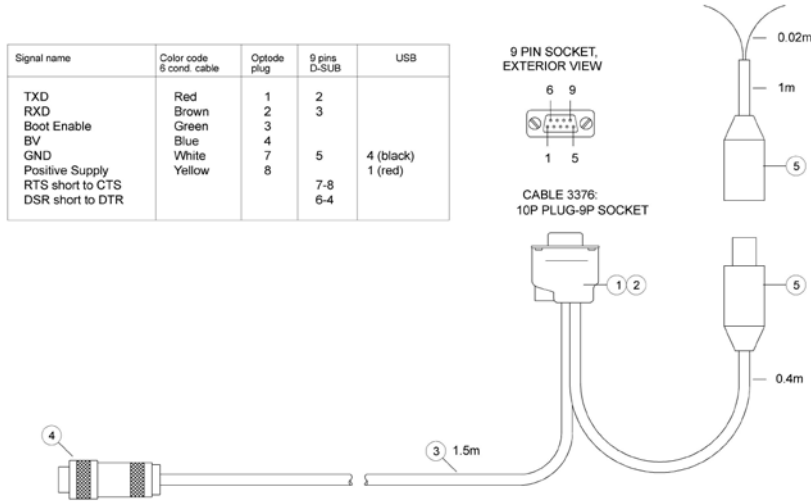

Figure A 10 Drawing Cable 3855.

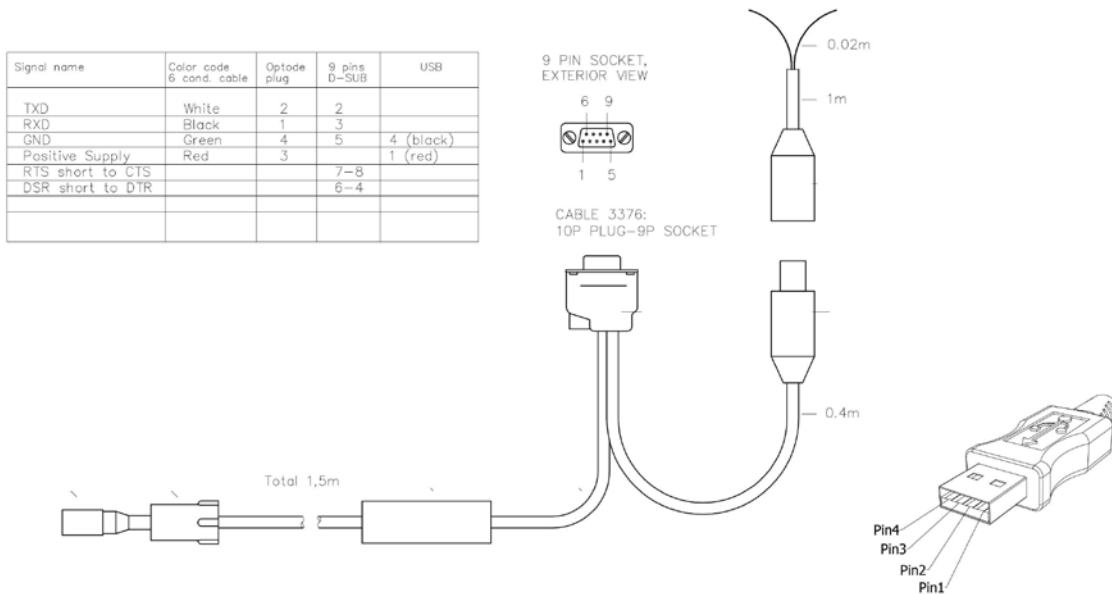

Figure A 11 Drawing Cable 5335

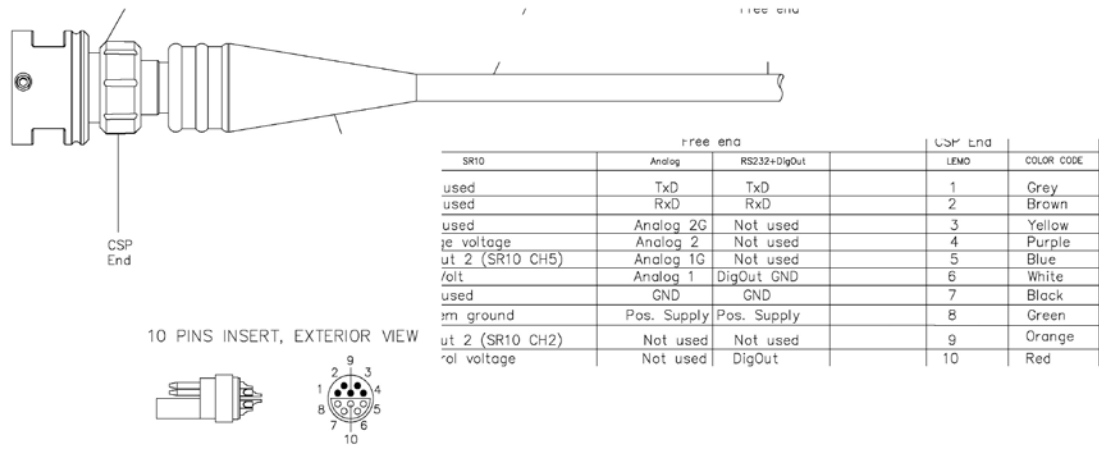

Figure A 12 Drawing Free end Cable 4762

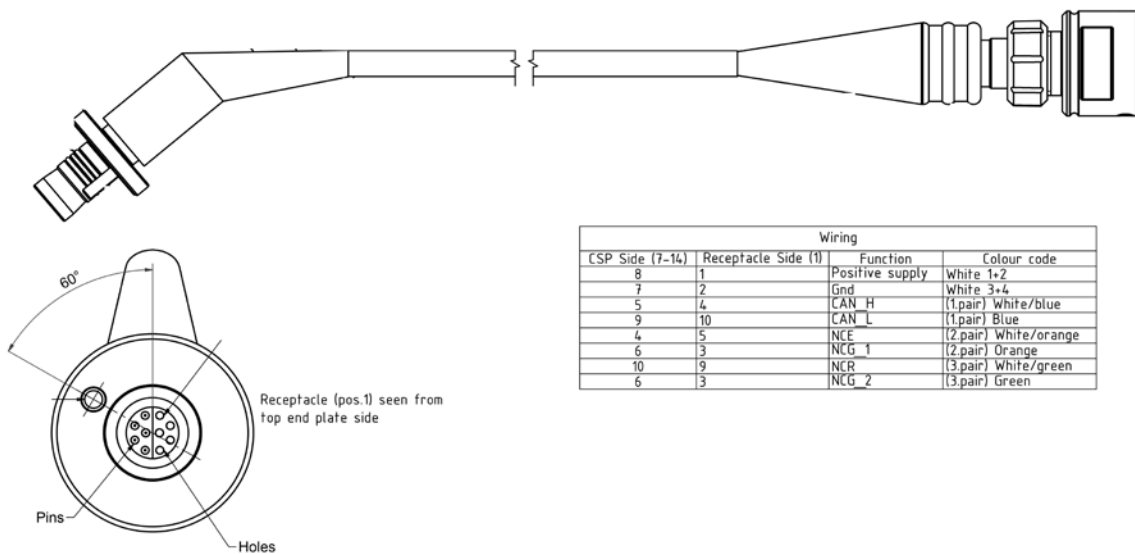

Figure A 13 Drawing Cable 4793

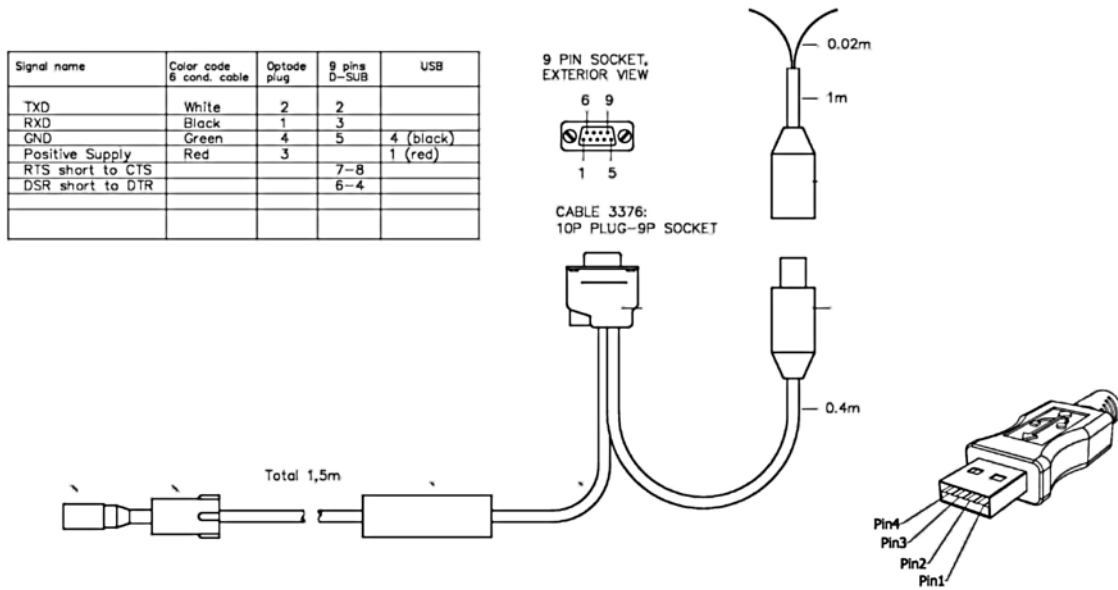

Figure A 14 Drawing Cable 5335

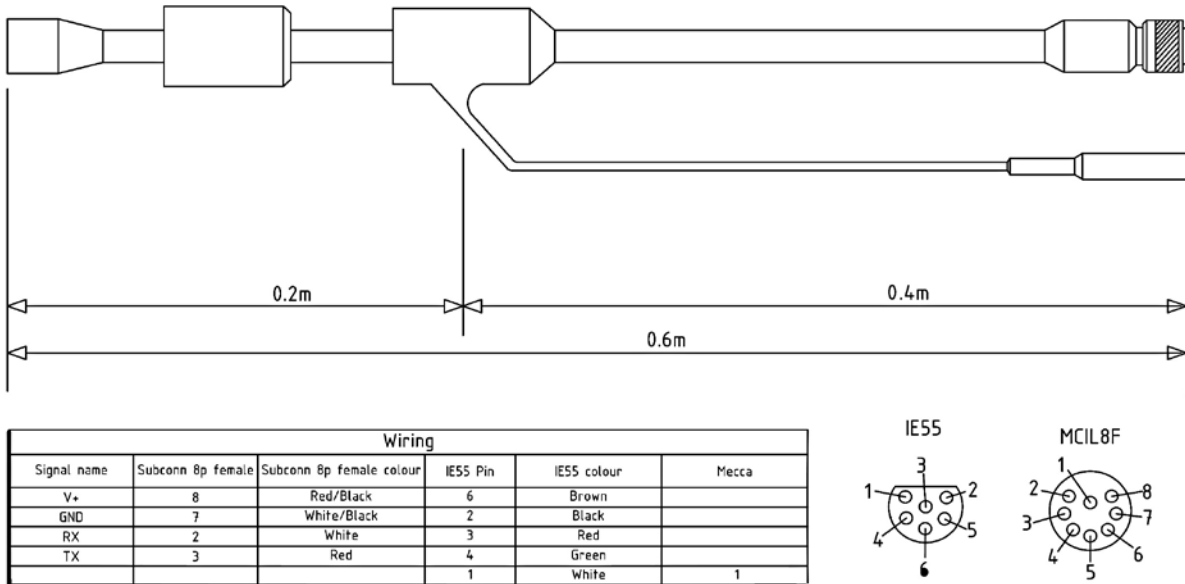
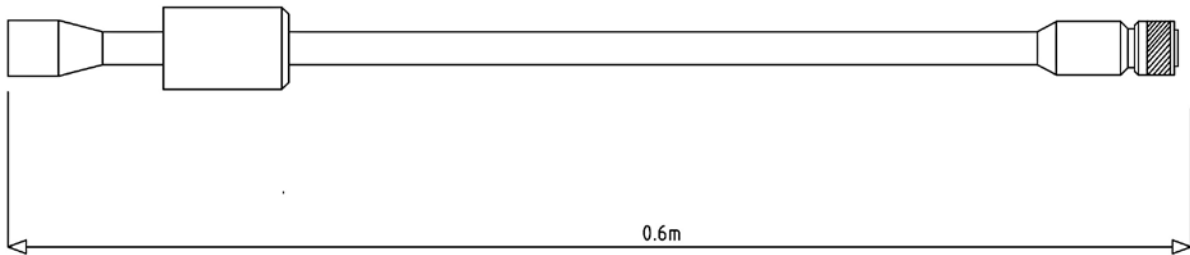

Figure A 15 Drawing Cable 5336



Wiring				
Signal name	Subconn 8p female	Subconn 8p female colour	IE55 Pin	IE55 colour
V+	8	Red/Black	4	Green
GND	7	White/Black	1	White
RX	2	White	2	Black
TX	3	Red	5	Blue

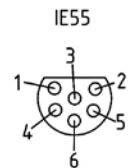
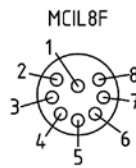

Figure A 16 Drawing Cable 5280

Appendix 9 Frequently Asked Questions –FAQ

In this chapter we present a copy of our FAQ for the Optodes. The latest version is on our web site, refer www.aanderaa.com

IMPORTANT! This FAQ is general for all versions of AADI Oxygen Optodes; all features described in the FAQ are not available for all Optode versions.

Calibration, Calibration Coefficients, Accuracy and Precision

CCAP1

Q: What calibration coefficients are used in the sensor, how can I make sure that I use the correct ones?

A: The sensor has several sets of calibration constants stored in its memory.

These can be verified from your PC via the AADI Real-Time Collector software or with a terminal communication program like Hyperterminal or Tera Terminal.

The coefficients are:

1. The internal temperature sensor has its own calibration constants that do not need to be changed by the user.
2. The sensing foil has a set of 28 constants C_0 to C_4 (FoilCoefA₀₋₁₃, FoilCoefB₀₋₁₃ for Optode 4330 and 4835), which are specific to that batch of foils (normally produced in batches of 100). If you change the foil with a foil from a different batch you must update the foil constants stored in the sensor with a set of new constants by entering them manually into the sensor.
These constants are delivered on a calibration certificate together with the new foil. For multipoint calibrated Optodes the SVU(Stern Volmer Uchida) formula is used for describing the relationship between phase shift/temperature and oxygen concentration. (Enable SVUformula set to 'yes'). The coefficients in this formula are stored in the SVUFoilCoef property_{0..6}.
3. In order to adjust for sensor to sensor variation linear correction of the O₂ concentration is used. This offset and slope coefficients are stored in ConcCoef₀ and ConcCoef₁ respectively. When performing a two point calibration these coefficients will be updated automatically and stored in the sensor. When changing or removing the foil a new calibration must be performed to obtain accuracy.
The most efficient way to do this calibration is to use the OxyView software or for 4330, 4831 and 4835 a terminal program like HyperTerminal or Tera Terminal (ref. Manual of these sensors for detailed instructions)
4. When data from the sensor is registered on an Aanderaa data-logger (e.g. on a RCM 9, a buoy etc.) the old Aanderaa specific SR10 format is used.
These readings then need to be post-processed (converted to the desired engineering units) by multiplying with a constant.
This constant is obtained by dividing the range by the 10-bit resolution of the SR10 format.
If you have selected to output oxygen concentration in μM in the SR10 format you will have to multiply the obtained data by 0.488281.
If you select to output % saturation you will have to multiply with 0.146484. If logging the sensors with SEAGUARD[®] and/or Smartguard (4330 or 4835) loggers using the AiCap communication protocol will automatically give out calibrated data with full resolution when connected to the logger. The same is true if logging the sensor with serial communication.
5. Converting the analog output signal (4831 or via Analog Adaptor 3966) will normally require use of scaling coefficients. These coefficients are dependent on for which parameter and range the

outputs are configured. When the Optode is configured to analog output mode these coefficients will be presented at the RS232 interface at power up or reset.

CCAP2

Q: If I change the foil and forget to update the internal constants but I made a new calibration can I back-calculate to get the correct data?

A: If the foil is from the same batch it will have the same constants and the data should be ok. If the foil is not from the same batch it will not be possible to post-compensate the obtained data.

It is imperative to use the correct foil constants and to do a new two-point calibration if the foil has been changed or moved.

CCAP3

Q: On the paper the specifications of the AADI Optodes appears to be conservative compared to specifications given for other sensors on the market, why?

A: After calibration the sensors normally perform better than the given specifications.

Aanderaa has a tradition to be conservative when giving sensor specifications so that these reflect the performance in the field not the best specifications you can obtain in the laboratory.

CCAP4

Q: Can the accuracy of the sensor be further improved?

A: Yes, if the individual sensor was calibrated in more calibration points (e.g. 30-40 point calibration), both with respect to oxygen concentration and temperature compensation of the foil, the accuracy would be improved by approximately a factor of 4.

Starting in the first half of 2012 AADI offers a multipoint factory calibration which give absolute accuracies of $\pm 2 \mu\text{M}$ or $\pm 1.5 \%$ over the whole range of temperatures and oxygen concentrations. Some customers have also established their own calibration procedures.

CCAP5

Q: How often do I need to re-calibrate the sensor?

A: If the foil is not mechanically damaged or moved no recalibrations are normally needed.

In our documentation we recommend a recalibration once a year but ample field experiences have demonstrated that these optodes are stable over much longer time periods than this. The longest field deployments without sensor drift has lasted 6 years.

It has however been concluded that when sensor foils are new they go through a maturation process that can last for approximately 1 month. The maturation will lead to lower readings and explain why some of the delivered sensors read some % lower than when they were calibrated.

When you receive the sensor from the factory no calibrations are needed but of course you should check that it is working properly

CCAP6

Q. The brochure says accuracy of $8 \mu\text{M}$ or 5% (whichever is greater).

Does this mean that at very low levels the accuracy is 5% of the measurement?

A: No, this means that the accuracy is $8 \mu\text{M}$ for readings below $160 \mu\text{M}$ and 5% for readings above $160 \mu\text{M}$. Starting in the first half of 2012 AADI offers a multipoint factory calibration which give absolute accuracies of $\pm 2 \mu\text{M}$ or $\pm 1.5 \%$ over the whole range of temperatures and oxygen concentrations.

CCAP7

Q: Is there a minimum measuring point or will the sensor go all the way down to zero?

A: It will go all the way to 0. There is no minimal measuring point. If a calibrated Optode reads a constant low value (e.g. from -1 to 1 μM) when the oxygen level in reality is 0 it most likely reflects an inaccuracy in the zero point calibration or in the temperature compensation.

CCAP8

Q: When calibrating, which substance should I use to remove the oxygen in the water?

A: At Aanderaa we use Sodium sulphite for this purpose.

Sodium sulphite rapidly removes the oxygen and as long as crystals of the compound can be seen the oxygen level in the water will stay at 0. Sodium sulphite also has the advantage of being inexpensive and the level of toxicity is low.

There are many other chemical substances that could be used for the same purpose.

Some investigators use Sodiumdithionit, which is also effective but more expensive and more toxic.

Bubbling with gases (e.g. N_2 , Argon etc) will also “strip off” the oxygen from the water but this takes longer time and sometimes, especially if the water volume is large, it can be difficult to know when a true zero oxygen level has been reached.

Another way of removing gas/air/oxygen from water is to boil it for at least 15 minutes and let it cool off in a gas tight vial (e.g. of glass). Be careful when opening the vial, exposure to the air will lead to immediate air contamination.

CCAP9

Q: When calibrating at saturation, which type of device should I use to get 100% saturation?

A: It is advisable to use standard aquarium equipment, which is normally inexpensive.

An aquarium pump connected to a tube which has been fitted with porous stone (bubble dispenser) at the end is suitable.

This will create small air bubbles that are efficient in equilibrating the water rapidly.

Be careful with using compressed air or compressor/vacuum type pumps since these are likely to compress the air/oxygen which will give errors when calibrating.

Normally the sensor will under-read after such a calibration.

A similar situation will occur if the sensor is calibrated in a “deeper” water tank.

If the air bubbling and the sensor are placed at for example 1 m water depth the over pressure will be approximately 10%.

CCAP10

Q: When calibrating which type of vials/containers should be used?

A: It is preferable to use clean glass vials, instead of plastic, for calibrations and any types of experiments.

There have been examples in which oxygen has either been consumed by substances bound into the plastic container walls or oxygen has diffused through the walls from the outside.

Glass is preferable for basically all applications that are dealing with dissolved gases.

CCAP11

Q: When sampling the sensors at high frequencies (1-10 s intervals) there appears to be some self-heating of the sensor.

What can be done to minimize the effects of the self-heating and how big is the effect of it?

A: The sensor has linear power regulators which mean that if you supply it with higher voltage (e.g. 8-14V) it will still consume the same amount of Amperes as at 5V.

The additional energy at higher voltages will be lost as heating which will contribute to the self-heating.

Therefore it is better to supply the sensor with 5V in high sampling frequency applications.

Laboratory testing at 5V has revealed that self-heating of the sensor can introduce a $1\mu\text{M}$ (giving lower readings than correct) when sampled at a 1 second sample-interval.

This error drops to $0.2\mu\text{M}$ for a 5 second interval. The error of the internal temperature sensor at a 5 s

sampling interval is approximately 0.03°C. At a 1 s sampling interval it is approximately 0.1°C. Care should be taken when using the sensor in on-line system applications (e.g. in a ferry box system). The internal temperature sensor is placed in the “foot” of the sensor (except for the 4330 and 4831 Optodes on which the temperature sensor has been moved close to the foil). If mounting the sensor in the wall of an on-line system that has high thermal conductivity (e.g. metal walls) with the outside this might give significant effects on the Optode temperature sensor, which also will lead to errors in the oxygen readings since these temperature readings are used for the necessary temperature compensation.

CCAP 12

Q. Is there a difference in the sensor response if the foil is wet or dry?

A. Yes the sensor is and should be calibrated in a wet environment and it takes hours for the foil to become completely wet or dry.

Taking a sensor which has been sitting in a dry environment for several hours and introducing it into water to make a spot measurement can lead to an error of maximum 2%.

Keeping the sensor in a humid environment for at least 12 h will eliminate this error.

If you would like to do spot measurements, where the sensor is out of the water most of the time, we recommend you to keep the sensor in a wet environment (such as a plastic bag with water) in-between measurements.

Please be aware of that the wetting effect is foil chemistry dependent. There are sensors from other manufacturers which can have wetting effects of up to 15 %.

Measurement Related

MR 1

Q: Can I measure oxygen in air with the sensor?

A: Yes, but in dry air you should expect slightly higher readings since there is no water vapour present. The space normally taken by vapour in humid air is here replaced by more air and consequently the sensor should give slightly higher readings.

Please be aware that there is a high risk of having a different temperature at the foil compared to the temperature of the incorporated temperature sensor in air.

This might lead to errors in the temperature compensation and to readings that are not correct.

MR 2

Q: What is the reason that several sensors plunged into the same water do not give exactly the same values?

A: Depending on the given accuracy of the sensor which is mainly dependent on if it was two or multipoint point calibrated (see above) differences (within specifications) between sensors should be expected. There have also been cases when the user had not mixed the water well and consequently the oxygen concentrations were different at different locations in the water bath.

MR 3

Q: What physical factors will affect the sensor?

A: Temperature (which is already internally compensated), salinity (see below or Operating Manual) and pressure (see below or Operating Manual).

The two latter parameters are easily compensated for by simple formulas which are common for all sensors.

MR 4

Q: What chemical factors/elements will affect the sensor?

A: There exists no cross sensitivity for carbon dioxide (CO₂), hydrogen sulphide (H₂S), ammonia (NH₃), pH, any ionic species like sulphide (S₂⁻), sulphate (SO₄²⁻) or chloride (Cl⁻).

The sensors can also be used in methanol- and ethanol -water mixtures as well as in pure methanol and ethanol.

It should not be used in other organic solvents, such as acetone, chloroform or methylene chloride, which may swell the foil matrix and destroy it.

Interferences (cross-sensitivity) are found for gaseous sulphur dioxide (SO₂) and gaseous chlorine (Cl₂).

MR 5

Q: Is the sensor sensitive to H₂S?

A: No, it is not. It will not be damaged by H₂S and it is not cross-sensitive to it.

If H₂S is present the oxygen concentration should be zero or very close to zero since O₂ and H₂S rarely coexists, especially over longer time periods. There are examples in which AADI optodes have been deployed for almost 2 years in H₂S rich environments without any detectable damage or drift.

MR 6

Q: What is the pressure behaviour of the sensor?

A: The pressure effect is that the sensor reads 3.2% lower readings/1000 meters of water depth which means that at 1000 meters you will have to multiply your readings with 1.032 to get the correct absolute values and at 2000 meters with 1.064 etc.

This effect is the same for every sensor, it is linear and fully instantaneously reversible, when the pressure is released. The pressure effects were investigated in detail by Uchida et al. (2008). Please note that the pressure effect is foil dependent. Optodes from some other manufacturers will most likely not have the same behaviour.

MR 7

Q: What about hysteresis?

A: As opposed to electrochemical sensors and optodes from some other manufacturers the AADI optodes does not suffer from hysteresis (irreversible pressure effects).

The pressure effect on the sensor described above immediately disappears when the pressure is released.

MR 8

Q: Can I log data of oxygen concentration, oxygen saturation and temperature simultaneously on the old AADI SR10 output (e.g. on a RCM9/RCM11/Buoy with 3660 data logger etc.).

A: No, the Optode only has one SR-10 output channel.

You can either select to log oxygen concentration or oxygen saturation on your instrument.

To see how this set-up is done see the Operating Manual for 3830 and 3835 optodes or the OxyView software.

If you also would like to log the Optode's internal temperature sensor you will have to order the Oxygen Optode model 3930 which can output the temperature in parallel in VR22 format.

Note this is normally not necessary as our recording instruments include a separate temperature sensor.

Newer optodes e.g. 4330, 4831 and 4835 do not have SR10 output. When connected to data loggers (using AiCaP/CAN and/or RS232 format) all data coming from the sensor can be presented and logged including: O₂ concentration, O₂ saturation, Temperature and Raw data.

MR 9

Q: Why is the sensor limited to a range of 0-120% and 0-500 µM?

A: These limitations are only present when logging the sensor in SR10 or analog formats.

If logging the sensor in RS232 or AiCaP/CAN bus there are no upper limits for the measurements range.

However the user should be aware of that the sensors and the foils are normally only calibrated to 500µM beyond these limits a lower accuracy and precision should be expected.

AADI has however made several special deliveries of multipoint calibrated optodes that can measure with maintained accuracy up to 500 % air saturation. To calibrate such sensors demands special efforts and consequently are more costly.

The 120% saturation limit is given for extreme conditions, which will rarely occur in reality.

At 0°C at a salinity of 0 ppt the 100% saturation reading of water is 457µM.

It is unlikely that in such waters there would be supersaturation. seawater (35 ppt) at 0°C contains 358µM at 100% saturation so here there is margin of up to 140% before the sensor reaches the SR10 measuring limit of 500µM.

To conclude the limitation when logging the sensor in SR10 or analog format is 500µM = 16mg /l the corresponding saturation limitations in % can be calculated when the temperatures and salinities are known.

MR 10

Q: How fouling sensitive is the sensor?

A: The sensor does not consume any oxygen and it is not stirring sensitive therefore it is less sensitive to fouling than electrochemical sensors. Field experiences from parallel deployments have also demonstrated that the Optodes typically can measure without effects of fouling for twice as long as the AADI conductivity sensors.

The fouling sensitivity varies from case to case.

In the marine environment with high fouling conditions an unprotected Optode will give accurate readings as long as the fouling is not changing the local oxygen conditions around the sensing foil.

Some user experiences have shown that this, in the worst cases, can start to occur already after 10 days in warm and highly productive waters.

Customers have adapted different strategies to improve the fouling resistance including copper lining and wipers.

MR 11

Q: For how long time can you run the sensor before it will not work anymore?

A: The most critical limitation for the operational time (foil life) is foil bleaching.

When excited for a long time with strong blue light the foil will bleach and eventually reach a stage where the amplitude of the returning signal (even if it is lifetime based) will be too weak to be registered.

Laboratory tests at 2-second intervals have shown that the sensor can measure more than a year with this interval setting.

This means that the sensors can for example be operated for 5 years at a 10-second interval without any amplitude effects.

Exposure to direct sunlight will also excite/bleach the foil over time however this effect is minimal with the protection provided by the opaque/optical isolation layer on the standard responding foils.

The situation is radically different for the transparent fast response foils (can be used on the 4330 and 4831 sensors) These foils bleach if exposed to sunlight. This will lead to lower readings.

MR 12

Q: Can the 3830 sensor be used down to full ocean depth just by connecting it to a standard titanium connector from Aanderaa?

A: No, for high pressures, beyond 100 bar (1000 m), these are pressure rated to 600 bar (6000 m). Please look in the Operating Manual or contact Aanderaa for more information.

The 4831 Optode is delivered with a underwater matable Subcon connector which is pressure rated to

600 bar

MR 13

Q: Can I use the sensor for long-term measurements, in for example an on-line system, just by connecting it to a PC with the PC communication cable (model # 3855) that was delivered with the sensor?

A: Yes and No. It is not a problem to connect and log the sensor like this but you should be aware of that the connector on the cable is made out of anodized Aluminium that will start to corrode when it is used for too long times in salt water.

The sensor is of Titanium and will not corrode. For long-term applications you should use a Titanium connector. Please ask Aanderaa for more information.

MR 14

Q: The Aanderaa Optode and/or software appear to be programmed to only report per cent saturation relative to sea level.

How is it intended to take into account the barometric pressure, i.e., elevation, in reporting per cent saturation?

A: External calculation and post-processing must be used for calculating "real" saturation with respect to barometric/water pressure.

The Optode's internal software has not been prepared for measurements at high altitudes.

MR 15

Q: How high operation and storage temperature can the sensor stand?

A: Operating 0 to 40°C; Transport -40°C to 70°C, for storage we recommend room temperature or lower.

MR 16

Q: After calibration the maximum reading we can get in air at room temperature is 94.1 instead of 100. Do we need to replace the oxygen sensing foil?

A: The sensing foil does not need to be replaced.

The relative oxygen computed by the Optode is referred to standard atmospheric air pressure (1013.25 hPa).

The lower reading of 94.1 can be caused by that the saturation calibration of the Optode was done in a vial in which there was over saturation (e.g. because of the pump or because of non-stable temperature see also CCAP9) Another reason can be that your measurement is taken in an environment where the air pressure is lower than standard air pressure or that the oxygen concentration is lower.

See also question MR1.

You can find more about this topic in the operating manual.

MR 17

Q: Is there a difference in the sensor response if the foil is wet or dry?

A. Yes the sensor is and should be calibrated in a wet environment and it takes hours for the foil to become completely wet or dry.

Taking a sensor which has been sitting in a dry environment for several hours and introducing it into water to make a spot measurement can lead to an error of maximum 2%.

Keeping the sensor in a humid environment for at least 24 hours will eliminate this error.

If you would like to do spot measurements, where the sensor is out of the water most of the time, we recommend you to keep the sensor in a wet environment (such as a plastic bag with water) in-between measurements.

MR 18

Q. I have mounted my sensors in chambers.

When I immerge them into the water the response increases dramatically and already at 10m water depth I am measuring about twice the concentrations compared to what I am measuring at the surface.

What is happening?

A. The most likely explanation is that you have trapped air inside your chambers and that the sensors are measuring in this air.

At 10m water depth the partial pressure of oxygen is two times higher and this is what you are measuring.

MR 19

Q: I have mounted my sensors in chambers to make sediment-water incubations at the bottom.

The oxygen readings looks normal until the chambers are inserted into the sediment and the lids are closed.

Then it looks like, from the response of the Optodes, as if the oxygen concentrations increase.

What can the explanation be to this?

A. One possible explanation is that you have trapped air inside your chambers and when you close the lid it dissolves and change concentration in the now sealed chamber.

The effect becomes particularly visible if you are working in environments with low ambient oxygen concentrations.

Another explanation is that you use plastic chambers (Polycarbonate, Plexiglas) which act as efficient traps of air and oxygen (some plastic material can dissolve about 20 times more air than water).

To avoid this ventilate/equilibrate your chamber for several hours before closing the lid. **MR 20**

Q: I am measuring in the laboratory and the sensors are oscillating regularly with amplitude of a couple of μM .

The oscillations decrease when I immerse the sensors into air saturated water but they are still detectable.

What is the reason for these oscillations?

A. If exposed to the atmosphere the response of the sensors are directly affected by changes in air pressure.

If you are working in a laboratory which is equipped with an automatic climate control system the ventilation will most likely be turned on and off at regular intervals.

The operation of the ventilation will create air pressure changes in the room which are sensed by the Optodes.

It is important to think about this especially if you are calibrating sensors.

You have to take into account the local air pressure and if this is not the same inside your laboratory as at the air pressure you enter during calibration it will introduce errors.

If placing the sensor in a closed incubator the oscillations should not be detectable.

MR 21

Q: How do I convert oxygen data logged by the Optode to other units?

A: The Optode measures and presents data in micromole dissolved oxygen per liter ($\mu\text{mol/l}$). This unit is often also called micromolar (μM). Depending on the background and tradition of the user converting into other units might be useful.

To convert into mg/l the obtained values have to be divided by 31.25. To obtain ml/l the obtained values have to be divided by 44.66. To obtain $\mu\text{m/kg}$ the density of the water has to be calculated from temperature, salinity and pressure values that are measured in parallel with the oxygen.

For more specific information about this subject please look in: Methods of Seawater Analysis, 3rd Edition (1999). Klaus Grasshoff (Editor), Klaus Kremling (Editor), Manfred Ehrhardt (Editor). ISBN: 3-527-29589-5. Wiley.

MR 22

Q: What is the use of the phase, amp and rawTemp data in the long AiCap/RS232 data format when



a xylem brand

using the Optode in standalone mode?

Is there any diagnostic value in these data that would suggest foil aging, thermistor failure or otherwise indicate Optode service is required?

A: The initial reason for including these data as an option was mainly to have the possibility to quality check the internal calculations. For most users these data have no value and could be “turned off”. The comprehensive string of raw data can be limited to oxygen concentration, oxygen saturation and temperature by setting the output to 0 (zero). This can be done either by using the OxyView software or by transferring a three line command string using any terminal program (please refer to the manual). However, for investigators that are using the Optode on a fast profiling CTD it is recommended to use the CTD’s fast responding temperature sensor to temperature compensate the oxygen readings. To do this the Phase values have to be registered. For more specific information about how this is done please look at SSC13 in this FAQ and in the manual.

MR 23

Q: Why is salinity compensation needed?

A: As other oxygen sensors the Aanderaa Optodes are measuring the level of oxygen saturation (partial pressure) in the water and not the absolute concentrations. To get the absolute concentrations, the salinity has to be measured in parallel/known and compensated for. This can be done either internally by setting the salinity to a fixed value or externally by applying the formulas suggested by Garcia and Gordon (1992).

As a default value the internal salinity is set to 0 when Optodes are delivered from the factory. This setting can be changed by using the OxyView software or a standard terminal program (please see the operation manual for more information). The formulas from Garcia and Gordon (1992) that can be used to post compensate the measured values are also given in the Optode operation manual.

MR 24

Q: How does the air pressure influence the O₂ concentration?

A: If the air pressure is high (good weather or created by a ventilation system which gives over pressure) more oxygen can dissolve. For example if the air pressure is 1030 mbar compared to 990 mbar the saturation level will be $1030/990 = 1.04 = 4\%$ higher.

MR 25

Q: How does the salinity and temperature influence the O₂ concentration?

A: If the salinity and temperature are high, less oxygen can dissolve compared to if the salinity and temperature are low. For example: at 1000 mbar air pressure, a temperature of 20°C and a salinity of 35 ppt (typical for sea water) the water will reach an equilibrium concentration of 231 µM. At the same air pressure and temperature but at a salinity of 0 ppt (e.g. tap water) the saturation concentration will be 284µM.

Because the dissolution of a real gas does not follow the common gas law exactly, these concentrations are calculated with empirical formulas. Formulas that are frequently used (also by Aanderaa) are presented in: Garcia and Gordon (1992) Oxygen solubility in seawater: Better fitting equations. *Limnol. Oceanogr.* 37:1307-1312.

In the Optode manual calculation formulas and tables of oxygen solubility at different temperatures and salinities are presented. Please also ask us for our interactive Technical Documents in Excel format TD257 and TD280 which enables you to convert phase measurements to oxygen readings, to compensate for salinity and pressure changes, to calculate saturation levels and to convert between different oxygen units.

MR 26

Q: What is influencing the O₂ concentration in water?

A: In the laboratory how much oxygen that can be dissolved in the water is dependent on the salinity and temperature of the water and on the air pressure in the room.

If a glass of sterile water is left in a room with constant temperature and constant air-pressure, oxygen in the air will dissolve in the water according to the common gas law. After some time saturation equilibrium will be reached where no more oxygen can be dissolved in the water. If the water is stirred it will reach saturation faster. In reality it is difficult to reach equilibrium since temperature and air pressures do not stay constant.

When measuring in natural surface waters which are in contact with the atmosphere the following factors can influence the dissolved oxygen concentrations: 1. Temperature: when water is cooling off it becomes under-saturated and can take up more oxygen from the atmosphere, when it heats up it becomes oversaturated and releases oxygen. Efficient exchange between water and air takes place when there are waves. 2. Salinity: water with higher salinity can dissolve less oxygen. 3. Primary production: when e.g. phytoplankton and sea grass grow in the photic zone (where there is light) oxygen will be produced, this can lead to oversaturation. 4. Consumption/respiration: when there is no light phytoplankton consume oxygen and so do animals (e.g. zooplankton and fish) living in the water also when organic material is degraded by bacteria oxygen is consumed. 5. Waves: if waves are breaking they will entrain bubbles to deeper levels which dissolve and create higher oxygen concentrations.

When moving deeper, out of the zone where there is light and waves, oxygen can only be consumed and no oversaturation should be expected. In deeper waters oxygen changes are mainly related to water movements where water coming from below in most cases contains less oxygen. At the bottom, where organic material accumulates, oxygen consumption is the highest leading to sharper oxygen gradients when approaching the bottom. **MR 27**

Q: Does the sensor react to changes in salinity?

A: No, The sensor is measuring partial pressure and does not react to changes in salinity.

This can be verified by having two glasses of air-bubbled water, at the same temperature, next to each other.

One filled with freshwater (0 ppt) and the other with saltwater (e.g. 35 ppt).

When moving the sensor from one glass to the other it should read the same absolute oxygen concentration, in μm , even though the absolute oxygen solubility in the salt water is lower.

MR 28

Q: Does the % saturation level change with the salinity compensation?

A: No, the % saturation level should be the same.

MR 29

Q: I am going to have a deployment in ocean water with constant salinity (35 ppt). Is it possible to pre-set the internal setting in the sensor, to avoid post calibration?

A: Yes, this can be done. The default internal salinity is set to zero. If changing the internal salinity setting in the sensor (how this is done is described in the operating manual) to the correct value the sensor should give the correct absolute saturation concentration in the salt water.

This means that when working in waters with a constant and known salinity this value can be entered into the sensor prior to deployment.

MR 30



a xylem brand

Q: I measured dissolved oxygen in open water on a mooring with an Optode mounted on a SEAGUARD® current meter. It seems that at low currents (below 10 cm/s) oxygen readings have a tendency to drop to lower readings (negative excursions). Is this indicating that these sensors have difficulties measuring in low dynamic environments?

A: No, oxygen Optodes do not consume oxygen and are consequently not stirring sensitive. Metal structures submerged in water (of e.g. Stainless Steel, Aluminium, Bronze) are normally corrosion protected by sacrificial anodes. As the anode disintegrates oxygen is consumed at all "naked" exposed metal parts with which the anode is in electrical contact with. The oxygen consumption can be significant e.g. during its lifetime, normally 1-2 years, a 130 g Zn anode mounted on a SEAGUARD®/RDPC/RCM pressure case can consume all oxygen in about 700 l of water. Water parcels with lower oxygen concentrations will form and can surround the oxygen sensors and lead to artificial dips in the oxygen readings. These effects are detectable in environments in which oxygen is stable (e.g. less than 2 % variations over time periods of days-weeks) and when water currents are low (e.g. below 10 cm/s). In a vast majority of applications these effects are of low/no significance.

Mechanical and Maintenance

MM 1

Q: How do I clean the foil after a deployment if it has been fouled?

A: In all cases the cleaning procedure should be done with caution so that the protective foil coating (applies to slower responding foils) is not removed.

If the fouling is calcareous it can normally be dissolved with household vinegar (essig in German, eddik in Norwegian).

Another substance that can be used is commercially called muriatic acid, which is a 5% HCl solution (dilute solution by 50% should be tested to see how well it dissolves growth before using a stronger concentration).

If needed, use cotton covered Q-tips (normally for cleaning of ears) to gently wipe off the remains after it has been softened by soaking in vinegar/HCl. Optode can be submerged in vinegar/HCl overnight, or longer.

After cleaning the sensor it should be rinsed well in clean tap water before storing or reuse.

Do not use any organic solvents such as: Acetone, Chloroform and Toluene since these and others will damage the foil.

MM 2

Q: My foil has been damaged so that I can see scratches in the black protective layer and some blue light is coming out when measuring.

Do I need to change the foil?

A: No, normally not.

Even if quite heavily damaged the foil continues to work, in most cases. Caution should however be taken for transparent (fast response foils) and foils with a damaged black layer to keep them out of sunlight that could bleach the sensing layer.

As long as enough of the fluorophore remains on the foil the sensor will measure correctly.

If heavily damaged it is however recommended to recalibrate the sensor (with a standard two point calibration, see Operating Manual or OxyView software).

If the sensor behaves normally when placed in an air-bubbled water solution (showing around 100 % saturation) the foil should be ok.

If the foil is not ok the sensor will return values that are illogical to what should be expected.

Then the foil needs to be exchanged, new calibration constants entered and a new two point calibration performed.

Remember that the Optode sensors can also be operated with transparent foils so the black protective

layer is not essential.

If using a transparent foil it should then be noted that blue light will be spread out into the water.

This might induce primary production if measuring at a frequent time interval without moving the sensor.

MM 3

Q: I have an old RCM 7/RCM 8, can I mount the Optode and log it with this instrument?

A: No, the sensor does not fit physically on the top plate.

Neither will the RCM 7/8 be able to read the standard SR10 signal.

Response Time and Performance Checks

RTPC 1

Q: Why is the response time of the sensor slow?

A: It is slow because of two reasons.

First, the foil is covered with an opaque optical isolation layer to make it more rugged.

The optical isolation slows down the time it takes for oxygen to equilibrate within the foil.

Second, the response time of the temperature sensor, needed to compensate the optical readings, is also a limiting factor. In most long term applications the response time ($t_{63} < 25$ s) is sufficient but when doing fast profiling (e.g. with a CTD or on a towed vehicle) the response time can be a limiting factor. The 4330 and 4831 Optodes can be fitted with faster responding transparent foils that have approximately a factor 4 faster response.

RTPC 2

Q: What is the maximum sampling rate of the sensor?

A: 1 sample/second (1Hz).

If sampling at rates faster than 1 sample/5seconds please be aware of potential self heating errors (maximal error due to self heating 1-2 μ M).

When sampling at high rates it is better to power the sensor with 5 V (instead of higher tensions) to reduce the self heating (see above).

RTPC 3

Q: Can I check that the sensor is giving correct readings without doing any Winkler titration's?

A: Yes, if you have a glass of water that is open to the air and bubbled with an air pump (normally used in aquariums, compressor type pumps should be avoided) the water will rapidly become approximately 100% (96-104 %) saturated and it stays saturated if you continue the bubbling.

The bubbling also ensures mixing in the glass so that oxygen gradients do not form in the water.

The absolute concentration (in μ M or mg/l) in this water, at saturation, is dependent on three parameters: the salinity, the temperature and the air pressure.

For example if the salinity is 0 ppt and the temperature is 20°C the oxygen concentration should be around 284 μ M but this value is given for an air-pressure of 1013 mbar.

The saturation values can be obtained from tables and/or mathematical formulas given in the Operating Manual.

If the air pressure is higher, for example 1030, you should expect higher readings of about $(1030-1013) / 1013 = 27 / 1013 = 2.7\%$ and if it is lower the readings should be lower.

If you would like to go further with your tests you can vary the temperature in the glass either by adding ice or by heating the water.

The saturation should then stay close to 100% at all the times but the absolute concentration will increase when the temperature goes down and decrease when it increases.

Of course the sensor should drop to low readings when you bubble the water with a different gas than air or oxygen (e.g. N₂ or Argon). When you add for example Sodium sulphite to your water solution the sensor should read 0 oxygen.

Please note that it can take a long time before the water reaches a zero oxygen level when bubbling with gas.

Software, Settings, Communication and connection to various data loggers (including CTD's)

SSC 1

Q: How do I most easily communicate and use the sensor from my PC? How do I calibrate it and set it up?

A: Communication can be done with all Optodes using a standard Terminal program such as HyperTerminal (available in most Windows versions) or Tera Terminal. Please refer to optode manual for details. For earlier Optode versions (e.g. 3830 and 3835) the OxyView software can be used. This software is more or less self-explanatory and provides utilities, graphic & tabular display for set-up, calibration, logging etc. These functions are easily accessed without deeper knowledge about the sensor.

SSC 2

Q: Many new PC's do not have a serial port. How can I communicate with the sensor without this?

A: The only way to communicate with the sensor is through the serial port. There are adaptors available that convert from USB to serial port. Experience has shown that these do not always function out of the box and may not be fully compatible with Windows or with your computer's specific software. It is recommended that you download the latest drivers from the Internet site of the manufacturer of the USB/serial adaptor. It has turned out that the drivers delivered with the adaptor are not always up to date.

SSC 3

Q: Which COM port is normally used when I use an USB/serial adaptor.

A: This varies from PC to PC and it has to be found out in the operative system.

SSC 4

Q: Is OxyView required to change the sampling interval? If not, how is it done?

A: No. Communication and setting of sample intervals can all be done from a standard terminal program (like HyperTerminal). All this is explained in detail in the Operating Manual.

SSC 5

Q: What is the minimum supply voltage for the sensors?

A: The minimum supply is 5V the maximum is 14V.

SSC 6

Q: What is the peak current consumption for the sensors?

A: Less than 100mA (for 0.5 second).

SSC 7

Q: Is it possible to drive the Rx, Tx signals from the Optode directly by the 0-5V without a transceiver?

A: No, you must use RS-232 levels.

SSC 8

Q: When logging the sensor in RS232 format what is the minimum of signal lines we have to connect?

A: The minimum is four; TX, RX, Positive Supply and GND. For more information refer the Operating Manual.

SSC 9

Q: If you switch ON / switch OFF the power supply between the data acquisition, do you have to keep a delay time before acquiring some data or after a new switch ON?

A: Yes, the sensor will always do a sample after power up. The data output is after approximately 2 seconds. Approximately 2 seconds power off is needed to assure a new reset of the Optode. So in total it is recommended to supply power to the sensor for a minimum of 5 seconds during each sampling period.

SSC 10

Q: If I have internally set the sensors sample interval to 2 seconds and then decide to mount it on e.g. an RCM9 current meter, logging at a 1 hour sample interval, will there be a conflict between the sensor's internal interval and the one used by the RCM9?

A: No, there will not be any conflict. When the Optode is used with an Aanderaa data logger the power is only applied when the data-logger scans the connected sensors (Control Voltage is active). Every time the sensor is powered up, regardless of the internal interval settings, it will output one data reading (requires that the SR10 output is enabled, see Operating Manual for more information). The same happens for the AiCap/RS-232 output. Even if the sensor is set up for long measurement intervals it will output new data every time power is connected. If power is connected continuously the sensor will measure at the programmed time interval (anything from 1 second and upwards).

SSC 11

Q: I have connected the Optode to my Aanderaa current meter but no data is delivered from the sensor, why?

A: The Optode output has to be set to -1 or -2 to present data on the SR10 output channel. Please refer to the Operating Manual or the OxyView software for more information on how this is done.

SSC 12

Q: What should I think about if I want to use the Optode mounted on a water column profiling CTD or a towed vehicle?

A: In spite of the relatively slow response time with respect to these applications many customers have chosen to use the sensor mounted on a CTD, a profiling vehicle or a towed vehicle. Users have selected the Optode mainly because of the long-term stability and the absence of pressure hysteresis. Mainly pressure hysteresis makes electrochemical sensors unreliable when profiling at depths beyond 500-1000 meters. Whether the slow response time of the Optode will be an impediment to getting good data or not depends of course on how strong the gradients are and at what speed you are profiling/towing. Data from some successful profiling applications are presented in several peer reviewed scientific papers. For more information please look at the Aanderaa Internet pages.

SSC 13

Q: How should I connect and mount the sensor on for example a CTD or a towed vehicle?

A: If the CTD is equipped with a fast responding temperature sensor it is better to do the temperature compensation externally. This will improve the accuracy when subjected to fast temperature changes (when going through a gradient). The Optode must then be configured to output the phase shift information (Phase). Based on this data and the temperature data from the CTD, the oxygen concentration can be calculated with formulas (see the Operating Manual for details). If the CTD is not able to receive the RS-232 output, the Oxygen Optode 3975 or 4831 with analog output can be used. The two channel "intelligent" digital to analog converter supplied with this sensor is able to output two channels of your selection (including Phase). The Optode has normally been mounted on the lower part

of the CTD and with the window (where the foil is) close to a horizontal frame tube of the CTD. The hydrodynamic effect of the tube will then force water towards the foil and assures a good circulation both when going up and down. The Optode of course has to be connected to the CTD with a cable.

SSC 14

Q: When powered on does the Optode expect a "XON" command before it starts or does it just start sending data?

A: The Optode does not wait for an "XON" before it starts.

Appendix 10 List of scientific papers

Examples of scientific papers in which AADI optodes have been used and evaluated

(Last updated in January 2012)

Commercially available oxygen optodes for oceanographic application were introduced by AADI in 2002. The long-term stability (years) and reliability of these sensors have revolutionized oxygen measurements and several thousand are in use in applications ranging from streams to the deepest ocean trenches (11 000 m), from fish farms to waste water, from polar ice to hydrothermal vents. This document gives examples of published scientific investigations in which AADI optodes have played a central role.

The basic technique of the AADI Oxygen Optode, an evaluation of its functioning in aquatic environments and multivariate investigations on sensor cross-sensitivity were presented in Tengberg et al (2006). Other studies include use on autonomous Argo floats Joos et al (2003), Körtzinger et al (2004 and 2005), Johnson et al. (2010) and gliders (Nicholson et al., 2008), long-term monitoring in coastal environments with high bio-fouling (Martini et al., 2007), on coastal buoys (Jannasch et al., 2008), on Ferry box systems (Hydes et al., 2009), on cabled CTD instruments for profiling down to 6000 m including suggestions for improved calibrations, pressure effect and compensation for slow response (Uchida et al., 2008) and in chemical sensor networks (Johnson et al., 2007). Drazen et al. (2005) presented a novel technique to measure respiration rates of deep sea fish and Sommer et al (2008) described an automatic system to regulate oxygen levels and to measure sediment-water fluxes during in-situ sediment incubation at vent sites. Also Pakhomova et al (2007) and Almroth et al. (2009) used the same type of optodes on autonomous landers to perform sediment-water incubations, with and without the introduction of sediment resuspension. In Wesslander et al (2011) the dynamics and coupling of carbon dioxide (CO₂) and oxygen was investigated in coastal Baltic Sea waters and McGillis et al (2011) described a novel method to assess the productivity of a coral reef using boundary layer and enclosure methods. Champenois and Borges (2012) studied variations in community metabolism rates of a *Posidonia oceanica* seagrass meadow by continuous measurements of oxygen at three different levels during three years. Viktorson et al. (2012) used yearlong oxygen measurements at several Gulf of Finland locations to calibrate a 3D model for prediction of bottom water oxygen dynamics and the subsequent coupling of low oxygen conditions to release of sediment bound phosphorous. When this summary is written we know that several new papers are in the process of being published. Please look www.aanderaa.com for updates or contact us at aadi.info@xyleminc.com for the latest news.

Literature cited

1. Almroth E., A. Tengberg, H. Andersson, S. Pakhomova and P.O.J. Hall (2009) Effects of resuspension on benthic fluxes of oxygen, nutrients, dissolved inorganic carbon, iron and manganese in the Gulf of Finland, Baltic Sea. *Continental Shelf Research*, 29: 807-818.
2. Champenois W. and A. V. Borges (2012) Seasonal and interannual variations of community metabolism rates of a *Posidonia oceanica* seagrass meadow. *Limnology and Oceanography*, 57(1), 347–361.
3. Drazen J. C., L. E. Bird and J. P. Barry (2005) Development of a hyperbaric trap-respirometer for the capture and maintenance of live deep-sea organisms. *Limnology and Oceanography Methods* 3: 488-498.
4. Hydes D.J., M.C. Hartman, J. Kaiser and J.M. Campbell (2009) Measurement of dissolved oxygen using optodes in a FerryBox system. *Estuarine, Coastal and Shelf Science*, 83: 485-490.

5. Jannasch H.W., L. J. Coletti, K. S. Johnson, S. E. Fitzwater, J. A. Needoba and J. N. Plant (2008) The Land/Ocean Biogeochemical Observatory: A robust networked mooring system for continuously monitoring complex biogeochemical cycles in estuaries. *Limnology and Oceanography Methods*, 6: 263-273.
6. Johnson K. S., S. C. Riser and D. M. Karl (2010) Nitrate supply from deep to near-surface waters of the North Pacific subtropical gyre. *Nature, Letters*, Volume 465, 24 June 2010: 1062-1065.
7. Johnson K. S., J. A. Needoba, S. C. Riser and W. J. Showers (2007) Chemical Sensor Networks for the Aquatic Environment. *Chemical Reviews*, 107: 623-640.
8. Joos F., G.-K. Plattner, T. F. Stocker, A. Körtzinger and D.W.R. Wallace (2003) Trends in Marine Dissolved Oxygen: Implications for Ocean Circulation Changes and the Carbon Budget. *EOS*, 84, No. 21, 27, 197-201.
9. Körtzinger, A., J. Schimanski, and U. Send (2005) High-quality oxygen measurements from profiling floats: A promising new technique. *J. Atmos. Ocean. Techn.*, 22: 302-308.
10. Körtzinger, A., J. Schimanski, U. Send, and D.W.R. Wallace (2004). The ocean takes a deep breath. *Science*, 306: 1337.
11. Martini M., B. Butman and M. Mickelson (2007) Long-Term Performance of Aanderaa Optodes and Sea-Bird SBE-43 Dissolved-Oxygen Sensors Bottom Mounted at 32 m in Massachusetts Bay. *Journal of Atmospheric and Oceanic Technology*, 24: 1924-1935.
12. McGillis W. R., C. Langdon, B. Loose, K. K. Yates and Jorge Corredor (2011) Productivity of a coral reef using boundary layer and enclosure methods. *Geophysical Research Letters*, Volume 38: L03611.
13. Nicholson D., S. Emerson and C. C. Eriksen (2008) Net community production in the deep euphotic zone of the subtropical North Pacific gyre from glider surveys. *Limnology and Oceanography*, 53: 2226–2236.
14. Pakhomova S., P.O.J. Hall, A. Tengberg, A. Rozanov and A. Vershinin (2007) Fluxes of Iron and Manganese across the sediment-water interface under various redox conditions. *Marine Chemistry*, 107: 319-331
15. Sommer S., M. Türk, S. Kriwanek and O. Pfannkuche (2008) Gas exchange system for extended in situ benthic chamber flux measurements under controlled oxygen conditions: First application—Sea bed methane emission measurements at Captain Arutyunov mud volcano. *Limnology and Oceanography Methods* 6: 23-33.
16. Tengberg A., J. Hovdenes, J. H. Andersson, O. Brocandel, R. Diaz, D. Hebert, T. Arnerich, C. Huber, A. Körtzinger, A. Khripounoff, F. Rey, C. Rønning, S. Sommer and A. Stangelmayer (2006). Evaluation of a life time based optode to measure oxygen in aquatic systems. *Limnology and Oceanography Methods*, 4: 7-17.
17. Uchida H., T. Kawano, I. Kaneko and M. Fukasawa (2008) In-situ calibration of optode-based oxygen sensors. *Journal of Atmospheric and Oceanic Technology*, 25: 2271-2281.
18. Wesslander K., P. Hall, S. Hjalmarsson, D. Lefevre, A. Omstedt, A. Rutgersson, E. Sahlée and A. Tengberg (2011) Observed carbon dioxide and oxygen dynamics in a Baltic Sea coastal region. *Journal of Marine Systems* 86: 1–9.
19. Viktorsson L., E. Almroth-Rosell, A. Tengberg, R. Vankevich, I. Neelov, A. Isaev, V. Kravtsov, P.O.J. Hall (2012) Benthic phosphorus dynamics in the Gulf of Finland, Baltic Sea. *Aquatic Geochemistry*, in press.

Appendix 11 Product Change Notification: Framework 3

Copy of content in Product Change Notification Document ID: DA-50009-01 of date 09 December 2011:

Product(s) Affected:

Product Number	Product Name	From Serial No.
4050	Temperature Sensor	300
4060	Temperature Sensor	500
4017	Pressure Sensor	700
4117	Pressure Sensor	600
4319(A/B)	Conductivity Sensor	800
4330(F/A)	Oxygen Optode	1000
4420	ZPulse® Doppler Current Sensor	500
4520	ZPulse® Doppler Current Sensor	600
4646(R)	Pressure Sensor	600
4647(R)	Tide Sensor	600
4648(R)	Wave and Tide Sensor	600
4830	ZPulse® Doppler Current Sensor	100
4835	Oxygen Optode	300
4930	ZPulse® Doppler Current Sensor	100
4880(R)	Temperature Sensor	200
4930	ZPulse® Doppler Current Sensor	100

General Change Description:

Most of AADI's Smart Sensors utilized common communication protocols for use at the RS232 and RS422 interface. Two protocols are available; Smart Sensor Terminal protocol and the AADI Real Time protocol, where the Smart Sensor Terminal protocol is a simple ASCII command string based protocol and the AADI Real Time is an XML based protocol. To accommodate for higher security and future expansions both protocols will be updated when releasing Sensor Framework version 3 (common software for the above sensors). This notification aim to give an overview of the changes in the Smart Sensor Terminal protocol. Please refer to the specific Operating Manuals for further details and to Technical Description TD267a for updates in the AADI Real Time protocol.

Appendix 12 Oxygen Dynamics in Water

Seawater and Gases

Refer Unisense AS for tabulated physical parameters of interest to those working with micro sensors in marine systems:

<http://www.unisense.com/Default.aspx?ID=1109>

Tables

Refer Unisense AS for Gas tables with diffusion coefficients, solubility of oxygen in seawater, density of water versus temperature and salinity, and much more:

<http://www.unisense.com/files/PDF/Diverse/Seawater%20&%20Gases%20table.pdf>

Copies of Unisense AS tables for *solubility of oxygen in seawater* are given in Figure A 17, Figure A 18, and Figure A 19.

NOTE! Refer Unisens AS for more information about the tables.



Oxygen solubility at different temperatures and salinities of seawater
 Units:µmol

Salinity (%)	Temperature(°C)																				
	0.0	1.0	2.0	3.0	4.0	5.0	6.0	7.0	8.0	9.0	10.0	11.0	12.0	13.0	14.0	15.0	16.0	17.0	18.0	19.0	20.0
0.0	456.6	444.0	431.9	420.4	409.4	398.9	388.8	379.2	369.9	361.1	352.6	344.4	336.6	329.1	321.9	314.9	308.3	301.8	295.6	289.7	283.9
1.0	453.5	441.0	429.0	417.6	406.7	396.3	386.3	376.7	367.6	358.8	350.4	342.3	334.5	327.1	319.9	313.0	306.4	300.0	293.9	287.9	282.2
2.0	450.4	438.0	426.1	414.8	404.0	393.6	383.7	374.3	365.2	356.5	348.1	340.1	332.4	325.0	317.9	311.1	304.5	298.2	292.1	286.2	280.6
3.0	447.3	435.0	423.2	412.0	401.3	391.0	381.2	371.8	362.8	354.2	345.9	338.0	330.4	323.0	316.0	309.2	302.7	296.4	290.4	284.5	278.9
4.0	444.2	432.0	420.4	409.2	398.6	388.5	378.7	369.4	360.5	351.9	343.7	335.9	328.3	321.0	314.0	307.3	300.9	294.6	288.6	282.9	277.3
5.0	441.1	429.1	417.5	406.5	396.0	385.9	376.3	367.0	358.2	349.7	341.6	333.7	326.2	319.0	312.1	305.5	299.0	292.9	286.9	281.2	275.7
6.0	438.1	426.1	414.7	403.8	393.3	383.3	373.8	364.6	355.9	347.5	339.4	331.6	324.2	317.1	310.2	303.6	297.2	291.1	285.2	279.5	274.0
7.0	435.1	423.2	411.9	401.1	390.7	380.8	371.3	362.3	353.6	345.2	337.2	329.6	322.2	315.1	308.3	301.7	295.4	289.4	283.5	277.9	272.4
8.0	432.1	420.3	409.1	398.4	388.1	378.3	368.9	359.9	351.3	343.0	335.1	327.5	320.2	313.1	306.4	299.9	293.6	287.6	281.8	276.2	270.8
9.0	429.1	417.5	406.3	395.7	385.5	375.8	366.5	357.6	349.0	340.8	333.0	325.4	318.2	311.2	304.5	298.1	291.9	285.9	280.1	274.6	269.2
10.0	426.1	414.6	403.6	393.0	383.0	373.3	364.1	355.2	346.8	338.6	330.8	323.4	316.2	309.3	302.6	296.2	290.1	284.2	278.5	273.0	267.6
11.0	423.2	411.8	400.8	390.4	380.4	370.8	361.7	352.9	344.5	336.5	328.7	321.3	314.2	307.3	300.8	294.4	288.3	282.5	276.8	271.3	266.1
12.0	420.3	409.0	398.1	387.8	377.9	368.4	359.3	350.6	342.3	334.3	326.7	319.3	312.2	305.4	298.9	292.6	286.6	280.8	275.1	269.7	264.5
13.0	417.4	406.2	395.4	385.2	375.3	366.0	357.0	348.3	340.1	332.2	324.6	317.3	310.3	303.5	297.1	290.8	284.8	279.1	273.5	268.1	262.9
14.0	414.5	403.4	392.7	382.6	372.8	363.5	354.6	346.1	337.9	330.0	322.5	315.3	308.3	301.7	295.2	289.1	283.1	277.4	271.9	266.5	261.4
15.0	411.7	400.6	390.1	380.0	370.4	361.1	352.3	343.8	335.7	327.9	320.5	313.3	306.4	299.8	293.4	287.3	281.4	275.7	270.2	265.0	259.9
16.0	408.8	397.9	387.4	377.4	367.9	358.7	350.0	341.6	333.5	325.8	318.4	311.3	304.5	297.9	291.6	285.5	279.7	274.0	268.6	263.4	258.3
17.0	406.0	395.2	384.8	374.9	365.4	356.4	347.7	339.4	331.4	323.7	316.4	309.4	302.6	296.1	289.8	283.8	278.0	272.4	267.0	261.8	256.8
18.0	403.2	392.5	382.2	372.4	363.0	354.0	345.4	337.2	329.2	321.7	314.4	307.4	300.7	294.2	288.0	282.1	276.3	270.8	265.4	260.3	255.3
19.0	400.4	389.8	379.6	369.9	360.6	351.7	343.1	335.0	327.1	319.6	312.4	305.5	298.8	292.4	286.3	280.3	274.6	269.1	263.8	258.7	253.8
20.0	397.7	387.1	377.0	367.4	358.2	349.3	340.9	332.8	325.0	317.6	310.4	303.5	296.9	290.6	284.5	278.6	273.0	267.5	262.3	257.2	252.3
21.0	394.9	384.5	374.5	364.9	355.8	347.0	338.6	330.6	322.9	315.5	308.4	301.6	295.1	288.8	282.7	276.9	271.3	265.9	260.7	255.7	250.8
22.0	392.2	381.8	371.9	362.4	353.4	344.7	336.4	328.5	320.8	313.5	306.5	299.7	293.2	287.0	281.0	275.2	269.7	264.3	259.1	254.1	249.3
23.0	389.5	379.2	369.4	360.0	351.0	342.4	334.2	326.3	318.7	311.5	304.5	297.8	291.4	285.2	279.3	273.5	268.0	262.7	257.6	252.6	247.9
24.0	386.8	376.6	366.9	357.6	348.7	340.2	332.0	324.2	316.7	309.5	302.6	295.9	289.6	283.4	277.5	271.9	266.4	261.1	256.0	251.1	246.4
25.0	384.1	374.0	364.4	355.2	346.4	337.9	329.8	322.1	314.6	307.5	300.7	294.1	287.8	281.7	275.8	270.2	264.8	259.5	254.5	249.6	244.9
26.0	381.5	371.5	361.9	352.8	344.0	335.7	327.7	320.0	312.6	305.5	298.7	292.2	285.9	279.9	274.1	268.5	263.2	258.0	253.0	248.2	243.5
27.0	378.8	368.9	359.5	350.4	341.7	333.4	325.5	317.9	310.6	303.6	296.8	290.4	284.2	278.2	272.4	266.9	261.6	256.4	251.5	246.7	242.1
28.0	376.2	366.4	357.0	348.0	339.5	331.2	323.4	315.8	308.6	301.6	294.9	288.5	282.4	276.5	270.7	265.3	260.0	254.9	250.0	245.2	240.6
29.0	373.6	363.9	354.6	345.7	337.2	329.0	321.2	313.8	306.6	299.7	293.1	286.7	280.6	274.7	269.1	263.6	258.4	253.3	248.5	243.8	239.2
30.0	371.0	361.4	352.2	343.4	334.9	326.9	319.1	311.7	304.6	297.8	291.2	284.9	278.8	273.0	267.4	262.0	256.8	251.8	247.0	242.3	237.8
31.0	368.5	358.9	349.8	341.1	332.7	324.7	317.0	309.7	302.6	295.9	289.3	283.1	277.1	271.3	265.8	260.4	255.3	250.3	245.5	240.9	236.4
32.0	365.9	356.5	347.4	338.8	330.5	322.5	314.9	307.7	300.7	294.0	287.5	281.3	275.4	269.6	264.1	258.8	253.7	248.8	244.0	239.4	235.0
33.0	363.4	354.0	345.1	336.5	328.3	320.4	312.9	305.6	298.7	292.1	285.7	279.5	273.6	268.0	262.5	257.2	252.2	247.3	242.6	238.0	233.6
34.0	360.9	351.6	342.7	334.2	326.1	318.3	310.8	303.7	296.8	290.2	283.9	277.8	271.9	266.3	260.9	255.7	250.6	245.8	241.1	236.6	232.2
35.0	358.4	349.2	340.4	332.0	323.9	316.2	308.8	301.7	294.9	288.3	282.0	276.0	270.2	264.6	259.3	254.1	249.1	244.3	239.7	235.2	230.9
36.0	355.9	346.8	338.1	329.7	321.7	314.1	306.7	299.7	293.0	286.5	280.3	274.3	268.5	263.0	257.7	252.5	247.6	242.8	238.2	233.8	229.5
37.0	353.5	344.4	335.8	327.5	319.6	312.0	304.7	297.7	291.1	284.6	278.5	272.5	266.8	261.4	256.1	251.0	246.1	241.4	236.8	232.4	228.2
38.0	351.0	342.0	333.5	325.3	317.4	309.9	302.7	295.8	289.2	282.8	276.7	270.8	265.2	259.7	254.5	249.5	244.6	239.9	235.4	231.0	226.8
39.0	348.6	339.7	331.2	323.1	315.3	307.9	300.7	293.9	287.3	281.0	274.9	269.1	263.5	258.1	252.9	247.9	243.1	238.5	234.0	229.7	225.5
40.0	346.2	337.4	329.0	320.9	313.2	305.8	298.7	292.0	285.4	279.2	273.2	267.4	261.8	256.5	251.4	246.4	241.6	237.0	232.6	228.3	224.1

Figure A 17 Copy of Data Table 6 by Niels Ramsing and Jens Gundersen: 100% Oxygen Solubility @ 1013 mbar pressure





Oxygen solubility at different temperatures and salinities of seawater
 Units: $\mu\text{mol/l}$

Salinity (‰)	Temperature (°C)																				
	20.0	21.0	22.0	23.0	24.0	25.0	26.0	27.0	28.0	29.0	30.0	31.0	32.0	33.0	34.0	35.0	36.0	37.0	38.0	39.0	40.0
0.0	283.9	278.3	273.0	267.8	262.8	257.9	253.2	248.7	244.3	240.0	235.9	231.9	228.0	224.2	220.5	217.0	213.5	210.1	206.7	203.5	200.4
1.0	282.2	276.7	271.4	266.3	261.3	256.5	251.8	247.3	243.0	238.7	234.6	230.6	226.8	223.0	219.4	215.8	212.3	209.0	205.7	202.5	199.3
2.0	280.6	275.1	269.8	264.7	259.8	255.0	250.4	245.9	241.6	237.4	233.3	229.4	225.6	221.8	218.2	214.7	211.2	207.9	204.6	201.4	198.3
3.0	278.9	273.5	268.3	263.2	258.3	253.6	249.0	244.6	240.3	236.1	232.1	228.1	224.3	220.6	217.0	213.5	210.1	206.8	203.6	200.4	197.3
4.0	277.3	271.9	266.7	261.7	256.8	252.1	247.6	243.2	238.9	234.8	230.8	226.9	223.1	219.5	215.9	212.4	209.0	205.7	202.5	199.4	196.3
5.0	275.7	270.3	265.2	260.2	255.4	250.7	246.2	241.8	237.6	233.5	229.5	225.7	221.9	218.3	214.7	211.3	207.9	204.6	201.4	198.3	195.3
6.0	274.0	268.7	263.6	258.7	253.9	249.3	244.8	240.5	236.3	232.2	228.3	224.4	220.7	217.1	213.6	210.2	206.8	203.6	200.4	197.3	194.3
7.0	272.4	267.2	262.1	257.2	252.5	247.9	243.4	239.1	235.0	230.9	227.0	223.2	219.5	215.9	212.4	209.0	205.7	202.5	199.4	196.3	193.3
8.0	270.8	265.6	260.6	255.7	251.0	246.5	242.1	237.8	233.7	229.7	225.8	222.0	218.3	214.8	211.3	207.9	204.7	201.5	198.3	195.3	192.3
9.0	269.2	264.1	259.1	254.2	249.6	245.1	240.7	236.5	232.4	228.4	224.5	220.8	217.2	213.6	210.2	206.8	203.6	200.4	197.3	194.3	191.3
10.0	267.6	262.5	257.6	252.8	248.2	243.7	239.4	235.2	231.1	227.1	223.2	219.6	216.0	212.5	209.1	205.7	202.5	199.4	196.3	193.3	190.3
11.0	266.1	261.0	256.1	251.3	246.7	242.3	238.0	233.8	229.8	225.9	222.1	218.4	214.8	211.3	208.0	204.7	201.4	198.3	195.3	192.3	189.4
12.0	264.5	259.5	254.6	249.9	245.3	240.9	236.7	232.5	228.5	224.6	220.9	217.2	213.7	210.2	206.8	203.6	200.4	197.3	194.2	191.3	188.4
13.0	262.9	257.9	253.1	248.4	243.9	239.6	235.3	231.2	227.3	223.4	219.7	216.0	212.5	209.1	205.7	202.5	199.3	196.2	193.2	190.3	187.4
14.0	261.4	256.4	251.6	247.0	242.5	238.2	234.0	229.9	226.0	222.2	218.5	214.9	211.4	208.0	204.6	201.4	198.3	195.2	192.2	189.3	186.5
15.0	259.9	254.9	250.2	245.6	241.1	236.8	232.7	228.6	224.7	220.9	217.3	213.7	210.2	206.8	203.6	200.4	197.2	194.2	191.2	188.3	185.5
16.0	258.3	253.4	248.7	244.2	239.8	235.5	231.4	227.4	223.5	219.7	216.1	212.5	209.1	205.7	202.5	199.3	196.2	193.2	190.2	187.4	184.6
17.0	256.8	252.0	247.3	242.8	238.4	234.2	230.1	226.1	222.2	218.5	214.9	211.4	208.0	204.6	201.4	198.2	195.2	192.2	189.3	186.4	183.6
18.0	255.3	250.5	245.9	241.4	237.0	232.8	228.8	224.8	221.0	217.3	213.7	210.2	206.8	203.5	200.3	197.2	194.1	191.2	188.3	185.4	182.7
19.0	253.8	249.0	244.4	240.0	235.7	231.5	227.5	223.6	219.8	216.1	212.5	209.1	205.7	202.4	199.2	196.1	193.1	190.2	187.3	184.5	181.7
20.0	252.3	247.6	243.0	238.6	234.3	230.2	226.2	222.3	218.6	214.9	211.4	207.9	204.6	201.3	198.2	195.1	192.1	189.2	186.3	183.5	180.8
21.0	250.8	246.1	241.6	237.2	233.0	228.9	224.9	221.1	217.3	213.7	210.2	206.8	203.5	200.3	197.1	194.1	191.1	188.2	185.4	182.6	179.9
22.0	249.3	244.7	240.2	235.8	231.7	227.6	223.6	219.8	216.1	212.5	209.1	205.7	202.4	199.2	196.1	193.0	190.1	187.2	184.4	181.6	179.0
23.0	247.9	243.2	238.8	234.5	230.3	226.3	222.4	218.6	214.9	211.4	207.9	204.6	201.3	198.1	195.0	192.0	189.1	186.2	183.4	180.7	178.0
24.0	246.4	241.8	237.4	233.1	229.0	225.0	221.1	217.4	213.7	210.2	206.8	203.4	200.2	197.1	194.0	191.0	188.1	185.2	182.5	179.8	177.1
25.0	244.9	240.4	236.0	231.8	227.7	223.7	219.9	216.2	212.5	209.0	205.6	202.3	199.1	196.0	193.0	190.0	187.1	184.3	181.5	178.8	176.2
26.0	243.5	239.0	234.7	230.5	226.4	222.5	218.6	214.9	211.4	207.9	204.5	201.2	198.0	194.9	191.9	189.0	186.1	183.3	180.6	177.9	175.3
27.0	242.1	237.6	233.3	229.1	225.1	221.2	217.4	213.7	210.2	206.7	203.4	200.1	197.0	193.9	190.9	188.0	185.1	182.4	179.6	177.0	174.4
28.0	240.6	236.2	231.9	227.8	223.8	219.9	216.2	212.5	209.0	205.6	202.3	199.0	195.9	192.9	189.9	187.0	184.2	181.4	178.7	176.1	173.5
29.0	239.2	234.8	230.6	226.5	222.5	218.7	215.0	211.4	207.9	204.5	201.2	198.0	194.8	191.8	188.9	186.0	183.2	180.5	177.8	175.2	172.6
30.0	237.8	233.5	229.3	225.2	221.3	217.4	213.7	210.2	206.7	203.3	200.1	196.9	193.8	190.8	187.9	185.0	182.2	179.5	176.9	174.3	171.7
31.0	236.4	232.1	227.9	223.9	220.0	216.2	212.5	209.0	205.5	202.2	199.0	195.8	192.7	189.8	186.9	184.0	181.3	178.6	175.9	173.4	170.9
32.0	235.0	230.7	226.6	222.6	218.7	215.0	211.3	207.8	204.4	201.1	197.9	194.7	191.7	188.7	185.9	183.0	180.3	177.6	175.0	172.5	170.0
33.0	233.6	229.4	225.3	221.3	217.5	213.8	210.1	206.7	203.3	200.0	196.8	193.7	190.7	187.7	184.9	182.1	179.4	176.7	174.1	171.6	169.1
34.0	232.2	228.0	224.0	220.0	216.2	212.5	209.0	205.5	202.1	198.9	195.7	192.6	189.6	186.7	183.9	181.1	178.4	175.8	173.2	170.7	168.2
35.0	230.9	226.7	222.7	218.8	215.0	211.3	207.8	204.3	201.0	197.8	194.6	191.6	188.6	185.7	182.9	180.1	177.5	174.9	172.3	169.8	167.4
36.0	229.5	225.4	221.4	217.5	213.8	210.1	206.6	203.2	199.9	196.7	193.6	190.5	187.6	184.7	181.9	179.2	176.5	173.9	171.4	168.9	166.5
37.0	228.2	224.1	220.1	216.2	212.5	208.9	205.4	202.1	198.8	195.6	192.5	189.5	186.6	183.7	180.9	178.2	175.6	173.0	170.5	168.1	165.7
38.0	226.8	222.7	218.8	215.0	211.3	207.7	204.3	200.9	197.7	194.5	191.4	188.5	185.6	182.7	180.0	177.3	174.7	172.1	169.6	167.2	164.8
39.0	225.5	221.4	217.5	213.8	210.1	206.6	203.1	199.8	196.6	193.4	190.4	187.4	184.5	181.7	179.0	176.3	173.8	171.2	168.7	166.3	164.0
40.0	224.1	220.1	216.3	212.5	208.9	205.4	202.0	198.7	195.5	192.4	189.3	186.4	183.5	180.8	178.1	175.4	172.8	170.3	167.9	165.5	163.1

Figure A 18 Copy of Data Table 7 by Niels Ramsing and Jens Gundersen: 100% Oxygen Solubility @1013 mbar pressure





Oxygen solubility at different temperatures and salinities of seawater

Units:µmol/l

Salinity (%)	Temperature (°C)																				
	0.0	5.0	10.0	15.0	20.0	25.0	30.0	35.0	40.0	45.0	50.0	55.0	60.0	65.0	70.0	75.0	80.0	85.0	90.0	95.0	100.0
0.0	456.6	398.9	352.6	314.9	283.9	257.9	235.9	217.0	200.4	185.6	172.2	159.9	148.3	137.2	126.5	115.9	105.5	95.1	84.7	74.5	64.3
5.0	441.1	385.9	341.6	305.5	275.7	250.7	229.5	211.3	195.3	181.0	168.1	156.2	145.0	134.2	123.8	113.6	103.4	93.3	83.2	73.2	63.3
10.0	426.1	373.3	330.8	296.2	267.6	243.7	223.3	205.7	190.3	176.6	164.1	152.6	141.7	131.3	121.2	111.3	101.4	91.6	81.7	71.9	62.2
15.0	411.7	361.1	320.5	287.3	259.9	236.8	217.3	200.4	185.5	172.3	160.2	149.1	138.6	128.5	118.7	109.0	99.4	89.8	80.2	70.7	61.2
20.0	397.7	349.3	310.4	278.6	252.3	230.2	211.4	195.1	180.8	168.0	156.4	145.6	135.5	125.7	116.2	106.8	97.5	88.1	78.8	69.4	60.2
25.0	384.1	337.9	300.7	270.2	244.9	223.7	205.6	190.0	176.2	163.9	152.7	142.3	132.4	123.0	113.7	104.6	95.5	86.4	77.3	68.2	59.2
30.0	371.0	326.9	291.2	262.0	237.8	217.4	200.1	185.0	171.7	159.9	149.0	139.0	129.4	120.3	111.3	102.5	93.6	84.8	75.9	67.0	58.2
35.0	358.4	316.2	282.0	254.1	230.9	211.3	194.6	180.1	167.4	155.9	145.5	135.7	126.5	117.7	109.0	100.4	91.8	83.2	74.5	65.8	57.2
40.0	346.2	305.8	273.2	246.4	224.1	205.4	189.3	175.4	163.1	152.1	142.0	132.6	123.7	115.1	106.7	98.3	90.0	81.6	73.1	64.7	56.3
45.0	334.4	295.8	264.6	238.9	217.6	199.6	184.2	170.8	159.0	148.3	138.6	129.5	120.9	112.6	104.4	96.3	88.2	80.0	71.8	63.5	55.3
50.0	323.0	286.1	256.3	231.7	211.3	194.0	179.2	166.3	154.9	144.7	135.3	126.5	118.2	110.1	102.2	94.3	86.4	78.5	70.5	62.4	54.4
55.0	311.9	276.7	248.2	224.7	205.1	188.5	174.3	161.9	151.0	141.1	132.1	123.6	115.5	107.7	100.0	92.4	84.7	77.0	69.2	61.3	53.5
60.0	301.3	267.7	240.4	217.9	199.1	183.2	169.6	157.7	147.1	137.6	128.9	120.7	112.9	105.4	97.9	90.5	83.0	75.5	67.9	60.2	52.6
65.0	291.0	258.9	232.8	211.3	193.3	178.1	165.0	153.5	143.4	134.2	125.8	117.9	110.4	103.1	95.8	88.6	81.4	74.1	66.6	59.2	51.7
70.0	281.0	250.4	225.5	204.9	187.7	173.0	160.5	149.5	139.8	130.9	122.8	115.2	107.9	100.8	93.8	86.8	79.8	72.6	65.4	58.1	50.8
75.0	271.4	242.2	218.4	198.7	182.2	168.2	156.1	145.6	136.2	127.7	119.9	112.5	105.5	98.6	91.8	85.0	78.2	71.2	64.2	57.1	50.0
80.0	262.2	234.2	211.5	192.6	176.8	163.4	151.9	141.7	132.7	124.6	117.0	109.9	103.1	96.4	89.9	83.3	76.6	69.9	63.0	56.1	49.1
85.0	253.2	226.6	204.8	186.8	171.7	158.8	147.7	138.0	129.3	121.5	114.2	107.3	100.8	94.3	88.0	81.6	75.1	68.5	61.8	55.1	48.3
90.0	244.5	219.1	198.3	181.1	166.7	154.3	143.7	134.4	126.0	118.5	111.5	104.9	98.5	92.3	86.1	79.9	73.6	67.2	60.7	54.1	47.5
95.0	236.2	211.9	192.1	175.6	161.8	150.0	139.8	130.8	122.8	115.6	108.8	102.4	96.3	90.2	84.3	78.2	72.1	65.9	59.6	53.1	46.6
100.0	228.1	205.0	186.0	170.3	157.1	145.8	136.0	127.4	119.7	112.7	106.2	100.0	94.1	88.3	82.5	76.6	70.7	64.6	58.4	52.2	45.8
105.0	220.3	198.2	180.2	165.1	152.5	141.7	132.3	124.0	116.7	109.9	103.6	97.7	92.0	86.3	80.7	75.0	69.3	63.4	57.4	51.2	45.1
110.0	212.7	191.7	174.5	160.1	148.0	137.7	128.7	120.8	113.7	107.2	101.2	95.4	89.9	84.4	79.0	73.5	67.9	62.1	56.3	50.3	44.3
115.0	205.4	185.4	169.0	155.2	143.7	133.8	125.2	117.6	110.8	104.5	98.7	93.2	87.9	82.6	77.3	72.0	66.5	60.9	55.2	49.4	43.5
120.0	198.4	179.3	163.6	150.5	139.5	130.0	121.8	114.5	108.0	102.0	96.4	91.0	85.9	80.8	75.7	70.5	65.2	59.8	54.2	48.5	42.8
125.0	191.6	173.4	158.5	146.0	135.4	126.3	118.4	111.5	105.2	99.4	94.1	88.9	83.9	79.0	74.0	69.0	63.9	58.6	53.2	47.7	42.1
130.0	185.0	167.7	153.4	141.5	131.4	122.8	115.2	108.5	102.5	97.0	91.8	86.9	82.0	77.3	72.5	67.6	62.6	57.5	52.2	46.8	41.3
135.0	178.7	162.2	148.6	137.2	127.6	119.3	112.1	105.7	99.9	94.6	89.6	84.8	80.2	75.6	70.9	66.2	61.3	56.4	51.2	46.0	40.6
140.0	172.6	156.9	143.9	133.1	123.8	115.9	109.0	102.9	97.3	92.2	87.4	82.9	78.4	73.9	69.4	64.8	60.1	55.3	50.3	45.1	39.9
145.0	166.6	151.7	139.4	129.0	120.2	112.7	106.0	100.2	94.9	90.0	85.4	80.9	76.6	72.3	67.9	63.5	58.9	54.2	49.3	44.3	39.2
150.0	160.9	146.7	134.9	125.1	116.7	109.5	103.2	97.5	92.4	87.7	83.3	79.0	74.9	70.7	66.5	62.2	57.7	53.1	48.4	43.5	38.6
155.0	155.4	141.9	130.7	121.3	113.3	106.4	100.3	95.0	90.1	85.6	81.3	77.2	73.2	69.1	65.1	60.9	56.6	52.1	47.5	42.7	37.9
160.0	150.1	137.2	126.5	117.6	110.0	103.4	97.6	92.5	87.8	83.4	79.3	75.4	71.5	67.6	63.7	59.6	55.4	51.1	46.6	42.0	37.2
165.0	144.9	132.7	122.5	114.0	106.7	100.5	94.9	90.0	85.5	81.4	77.4	73.6	69.9	66.1	62.3	58.4	54.3	50.1	45.7	41.2	36.6
170.0	139.9	128.3	118.7	110.5	103.6	97.6	92.3	87.6	83.4	79.4	75.6	71.9	68.3	64.7	61.0	57.2	53.2	49.1	44.9	40.5	36.0
175.0	135.1	124.1	114.9	107.2	100.6	94.9	89.8	85.3	81.2	77.4	73.8	70.2	66.8	63.3	59.7	56.0	52.1	48.2	44.0	39.7	35.3
180.0	130.5	120.0	111.3	103.9	97.6	92.2	87.4	83.1	79.1	75.5	72.0	68.6	65.2	61.9	58.4	54.8	51.1	47.2	43.2	39.0	34.7
185.0	126.0	116.0	107.8	100.8	94.8	89.6	85.0	80.9	77.1	73.6	70.3	67.0	63.8	60.5	57.1	53.7	50.1	46.3	42.4	38.3	34.1
190.0	121.7	112.2	104.3	97.7	92.0	87.0	82.7	78.7	75.2	71.8	68.6	65.4	62.3	59.2	55.9	52.6	49.1	45.4	41.6	37.6	33.5
195.0	117.5	108.5	101.0	94.7	89.3	84.6	80.4	76.7	73.2	70.0	66.9	63.9	60.9	57.9	54.7	51.5	48.1	44.5	40.8	36.9	32.9
200.0	113.5	104.9	97.8	91.8	86.7	82.2	78.2	74.6	71.4	68.3	65.3	62.4	59.5	56.6	53.6	50.4	47.1	43.6	40.0	36.3	32.4

Figure A 19 Copy of Data Table 8 by Niels Ramsing and Jens Gundersen: 100% Oxygen Solubility @1013 mbar pressure

